



SRA Series Scored Reverse-Acting Metal Rupture Disks

Disk Features

- Non-fragmenting design solid metal cross-scored disk
- Operating pressures to 90% of the disk's marked burst pressure
- Suitable for gas service only
- Disk is scored on the vent side to minimize the effect of product build up on the process side
- Burst ratings 20 to 1000 psig
- Sizes 1" thru 12"
- Temperature ratings to 900°F (482°C)
- Materials of construction: 316SS, Inconel, Monel, or Nickel
- 3-dimensional stainless steel tag is standard
- No Vacuum Support required
- Extended cycle life: withstands positive-to-negative cycling
- ASME UD marking available
- Use alone or combine with relief valves
- Unique notches in disk O.D. ensures proper mounting into SR7A Disk Holder



Disk Holder Features

- Insert type Rupture Disk Holder – designed exclusively to be used with the SRA Series Rupture Disk
- The SR7A Holder and Rupture Disk are assembled using safety designed side clips
- Standard materials of construction: 316SS and carbon steel. Other materials available upon request
- Permanently attached stainless steel nameplates are standard. Nameplates indicate flow direction and provide visual verification that holder assembly is properly oriented in the piping system
- Holder supplied with alignment pins and J-hook as standard
- Available options include: gauge tap; nipple and tee; excess flow valve; pressure gauge; J-hook; special facings and coatings

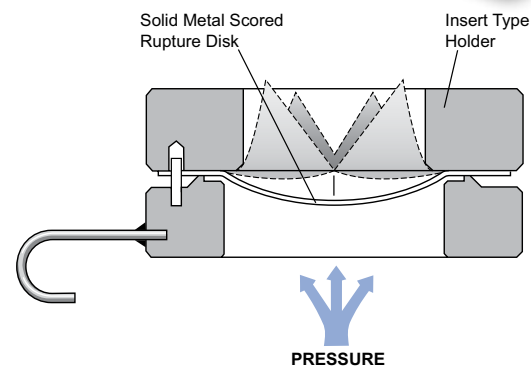

Options

TFE liners are available to provide protection from corrosive media if required.

Safety Relief Valve Protection

SRA Series Disks mounted under the valve isolate working parts from hostile environments.

SRA Series Disks mount with the convex surface facing the process media. As pressure increases above the recommended operating ratio, the compressive stress in the disk material increases until a point of instability is reached. At that point the disk begins to buckle. It tears along the score lines as it reverses, which initiates the complete rupture of the disk.



Safety through **knowledge** and **performance**.

SRA Series Specifications

Minimum and Maximum Pressure Ratings - psig (barg) @ 72°F (22°C)

Disk Size	Minimum Burst Pressure - psig @ 72°F (barg @ 22°C)					Maximum Burst Pressure	MNFA in ² (mm ²)
	With Liner (SRA-L)	316SS	Inconel	Monel	Nickel		
		Gas Services Only - A gas pocket is required below disk for liquid applications - Contact ZOOK for additional information					
1"	92	221	141	122	92	1480	0.86
25 mm	(6.34)	(15.24)	(9.72)	(8.41)	(6.34)	(102.04)	(554)
1-1/2"	81	234	98	98	81	1480	2.04
40 mm	(5.59)	(16.14)	(6.76)	(6.76)	(5.59)	(102.04)	(1,316)
2"	60	188	83	83	60	1480	3.36
50 mm	(4.14)	(12.97)	(5.72)	(5.72)	(4.14)	(102.04)	(2,167)
3"	55	154	66	65	55	1480	7.39
80 mm	(3.79)	(10.62)	(4.55)	(4.48)	(3.79)	(102.04)	(4,767)
4"	40	122	54	55	48	1480	12.73
100 mm	(2.76)	(8.41)	(3.72)	(3.79)	(3.31)	(102.04)	(8,212)
6"	35	94	47	44	35	800	28.89
150 mm	(2.41)	(6.48)	(3.24)	(3.03)	(2.41)	(55.17)	(18,638)
8"	33	▲	44	41	33	700	50.03
200 mm	(2.28)	▲	(3.03)	(2.83)	(2.28)	(48.28)	(32,277)
10"	30	▲	40	39	30	700	78.85
250 mm	(2.07)	▲	(2.76)	(2.69)	(2.07)	(48.28)	(50,870)
12"	27	▲	37	36	27	600	112
300 mm	(1.86)	▲	(2.55)	(2.48)	(1.86)	(41.38)	(72,257)
Max. Temp.	500°F (260°C)	900°F (482°C)	900°F (482°C)	800°F (427°C)	750°F (399°C)		

Notes: For materials, sizes, burst ratings and temperatures not shown, contact ZOOK
▲ - Not Available

SR7A Holder Dimensions Inches (mm)

Nominal Size	ASME B16.5 Flange Classes ■		Height
	Class 150 O.D.	Class 300/600 ▲ O.D.	
1"	2-1/2"	2-3/4"	1-7/8"
25 mm	(63.50)	(69.85)	(47.63)
1-1/2"	3-1/4"	3-5/8"	1-7/8"
40 mm	(82.55)	(92.08)	(47.63)
2"	4"	4-1/4"	1-7/8"
50 mm	(101.60)	(107.95)	(47.63)
3"	5-1/4"	5-3/4"	2-1/4"
80 mm	(133.35)	(146.05)	(57.15)
4"	6-3/4"	7" ▲	2-15/16"
100 mm	(171.45)	(177.80)	(74.62)
6"	8-5/8"	9-3/4" ▲	3-5/8"
150 mm	(219.08)	(247.65)	(92.08)
8"	10-7/8"	12" ▲	3-1/4"
200 mm	(276.23)	(304.80)	(107.95)

Notes:
■ Available to fit DIN and JIS flanges
▲ Contact ZOOK for flange class rating 600

Manufacturing Range / Burst Tolerance

Specified Burst Pressure Rating psig (barg)	Available Manufacturing Ranges	Burst Tolerance
40 and below	0%, -5%, -10%	+/-2.00
(2.76) and below		(+/-0.14)
Above 40		+/-5%
(Above 2.76)		(+/-5%)

Notes:
• 0% manufacturing range is standard. Disk will be marked with specified rating
• Burst tolerances are the maximum expected variation from the disk's marked burst pressure

TFE liner may be added to provide additional protection against corrosive media
Requirements / Limitations when TFE liner is added:
1. Max. temperature of 500°F (260°C) - Limitation of liner material
2. Liner may be applied to all ratings. Contact ZOOK if liner is required on both sides of rupture disk



SRA_012018

Visit us at www.zookdisk.com

SERVING AMERICA, CENTRAL & SOUTH AMERICA

16809 Park Circle Drive
Chagrin Falls, Ohio 44022
United States

Toll Free: +1 800 543 1043
Phone: +1 440 543 1010
Fax: +1 440 543 4930
E-mail: sales@zookdisk.com

SERVING EUROPE, MIDDLE EAST & AFRICA

Navigation House, Bridge St.
Killamarsh, Sheffield, S21 1AL
United Kingdom

Phone: +44 (0) 1909 560999
Fax: +44 (0) 1909 560860
E-mail: sales.europe@zookdisk.com

SERVING CANADA

4400 South Service Road
Burlington, Ontario, L7L 5R8
Canada

Toll Free: +1 800 370 6057
Phone: +1 905 681 2885
Fax: +1 905 681 8838
E-mail: sales.canada@zookdisk.com

SERVING ASIA PACIFIC

Unit No. 23A-05, Menara Landmark
No.12, Jalan Ngee Heng
80000 Johor Bahru, Johor,
Malaysia

Phone: +60 (7) 2910099
Fax: +60 (7) 2910096
E-mail: sales.asia@zookdisk.com



Safety through knowledge and performance.