

Dimension range DN 150 - 500	PN 10	Temperature range -30 °C to 110 °C	Material Stainless steel
--	-----------------	--	------------------------------------

Range of Application

For mechanical cleaning of warm water, cooling systems, oil and corrosive fluids.

PMB.211 Screen filter

Strainer AT 4054A. Stainless steel, straight bore, with flanges, PN 10. Mesh width ... mm.

Quality Assurance

Quality certificate SS-EN 10204, 2.2 (if stated in the order).

The mechanic calculations for the strainer does not take external forces into consideration.

CE-marking

AT 4054A meet the requirements of 8§ in AFS 2016:1 and 2014/68/EU (Pressure Equipment Directive).

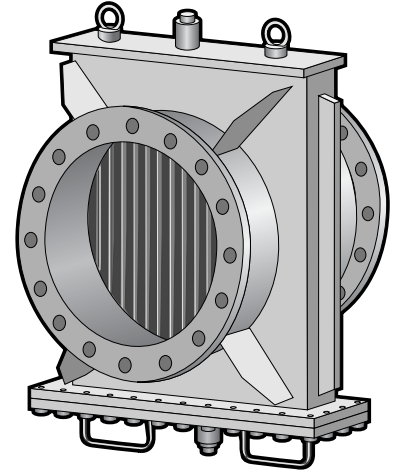

Material Specification

Pos	Component	AT 4054A
1	Body	Stainless steel 1.4301
2	Sieve	Stainless steel 1.4301
3	Cover gasket	O-ring Viton
4	Cover	Stainless steel 1.4301
5	Drain plug	Stainless steel 1.4301

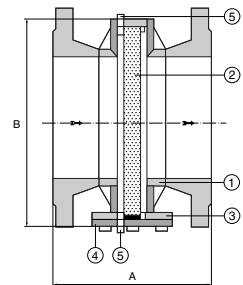

Dimension and Weight

DN	150	200	250	300	350	400	500
A Flanges	350	400	450	500	550	600	700
A Weld ends	240	276	310	344	385	430	520
B	475	475	475	475	595	595	595
Width	450	450	450	450	640	640	640
Weld end Od	168,3	219,1	273	323	355,6	406,4	508
Drain plug	G 3/4	G 3/4	G 3/4	G 3/4	G 1	G 1	G 1
Weight	85	95	117	124	200	220	280

Measurements in mm, weight in kg.

Function and Design

Effectively catches the solid particles that are larger than the perforation in the strainer insert. The insert is made of folded perforated steel, with a large free strainer area in relation to DN which gives a low pressure drop. Standard perforation is 1,0 mm for DN 150-300 and 2,0 mm for DN 350-500. Face to face dimension according to DIN 3202/1, F5 for the flanged version.

Technical Information

The pressure drop chart below is valid for water and a clean strainer insert and standard perforation.

For calculation of pressure drop for other kinds of media, use:

DN	150	200	250	300	350	400	500
K _{vs}	575	710	1240	1740	2350	2760	4660

Pressure drop chart

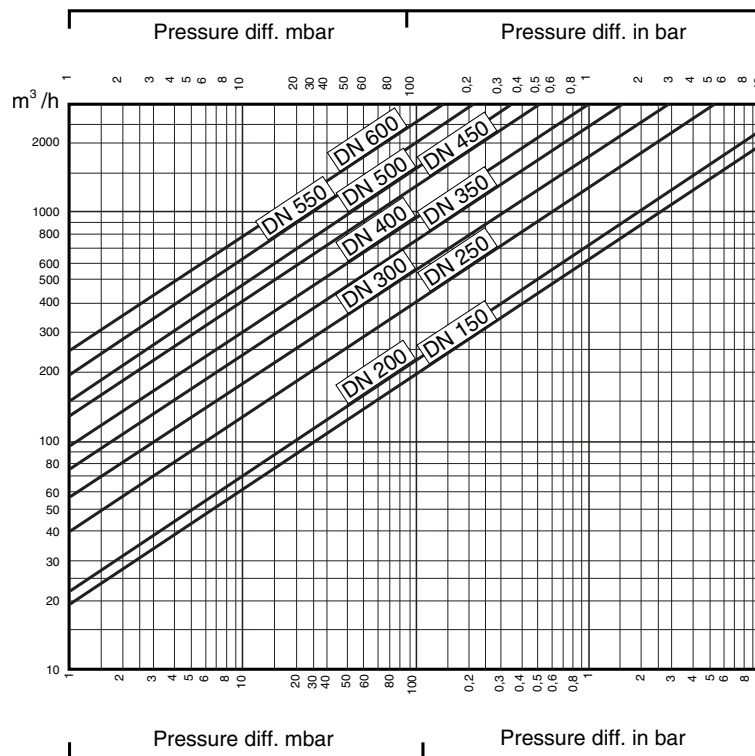

Pressure and temperature

	DN	Maximum pressure bar(g)	Working temp min/max °C
AT 4054A	150- 500	10	-30/110

Accessories and Options

Can be delivered with other perforations: 3,0, 5,0, 8,0, 10,0 mm.

Installation

Fig. No.	Connection
AT 4050AHT	Flanges acc. to SS 336-PN 25
AT 4051AHT	Welded ends
AT 4054A	Flanges acc. to SS 335-PN 10
AT 4055A	Welded ends

Rätten till ändringar utan föregående meddelande förbehålls.
 Armatec ansvarar inte för eventuella tryckfel eller missförstånd.
 Dokumentet får kopieras endast i sin helhet.

The strainer should be mounted in horizontal pipe for best function and easier cleaning of the strainer insert. Can be mounted with the cover either downwards or upwards as there is a drain plug in both ends. Note that the flow has to be according to the flow arrow on the strainer body.

Blow-out valves, for example AT 3600 or AT3535, can be mounted instead of the drain plug for simpler cleaning.

Maintenance and Spare parts

Highly increased pressure drop over the filter indicates that the strainer insert should be cleaned. Strainer inserts and cover gaskets are available as spare parts.

Marking

Manufacturer, DN, PN, material and flow arrow.

How to order

Example: AT 4051A500

AT 4051A	500
Fig.No.	DN
AT 4050AHT = flanges, steel	150-500
AT 4051AHT = welding ends, steel	150-500
AT 4054A = flanges, stainless steel	150-500
AT 4055A = welding ends, stainless steel	150-500