

Liquid ring vacuum pumps

in compact design

LEM 26, LEM 51

Pressure range: 33 to 1013 mbar
Suction volume flow: 3 to 58 m³/h

CONSTRUCTION TYPE

SIHI liquid ring vacuum pumps are displacement pumps of uncomplicated and robust construction with the following particular features:

- non-polluting due to nearly isothermal compression
- oil-free, as no lubrication in the working chamber
- handling of nearly all gases and vapours
- small quantities of entrained liquid can be handled
- easy maintenance and reliable operation
- low noise and nearly free from vibration
- wide choice of material, therefore applicable nearly everywhere
- protection against cavitation as standard
- incorporated dirt drain
- incorporated central drain
- no metallic contact of the rotating parts

The SIHI liquid ring vacuum pumps LEM are single-stage ones.

APPLICATION

Handling and exhausting of dry and humid gases; entrained liquid can be handled during normal duty. The pumps are applied in all fields where a pressure of 33 to 900 mbar must be created by robust vacuum pumps.

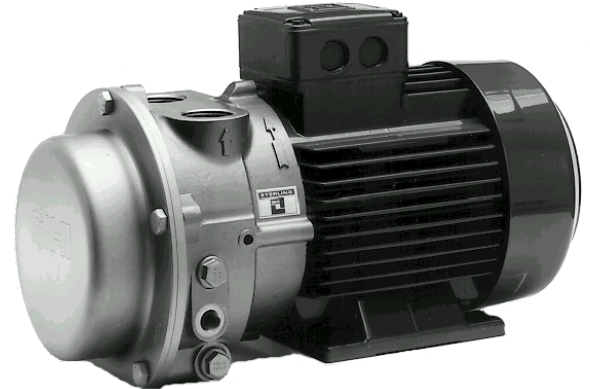

NOTE

During operation the pump must continuously be supplied with service liquid, normally water, in order to eliminate the heat resulting from the gas compression and to replenish the liquid ring, because part of the liquid is leaving the pump together with the gas. This liquid can be separated from the gas in a liquid separator (see catalogue part accessories).

It is possible to reuse the service liquid. The pumps are equipped with a device by which the contaminated service liquid can continuously be drained during operation (dirt drain), if necessary.

The direction of rotation is clockwise, when looking from the drive on the pump.

GENERAL TECHNICAL DATA

Pump type	units	LEM 26	LEM 51
Speed	50 Hz 60 Hz	rpm 2900 3500	
Maximum overpressure on compression	bar	0.3	
Permissible pressure difference between suction and discharge side	bar	1.1 0.2	
Hydraulic test pressure (overpressure)	bar	3	
Moment of inertia of rotating parts of pump and water content	kg · m ²	0.003	0.005
Noise level at 80 mbar suction pressure	dB (A)	68	
Maximum gas temperature	dry saturated	°C 200 100	
Service liquid:			
Maximum permissible temperature	°C	80	
Minimum permissible temperature	°C	10	
Maximum viscosity	mm ² /s	4	
Maximum density	kg/m ³	1200	
Liquid capacity up to middle of shaft	litre	0.4	0.6
Maximum flow resistance of the heat exchanger	bar	0.2	

In selecting a pump, avoid choosing one which is likely to be operating at a combination of its maximum permissible limits e.g. maximum viscosity and maximum permissible pressure difference.

Materials

Position number	COMPONENT	MATERIALS		
		0A	OK	4B
10.10	Vacuum casing	0.6025		1.4408
13.70	Guide disc	1.4301		1.4404
16.10	Cover			
23.50	Vane wheel impeller	2.1096.01	1.4308	1.4408 (LEM 26) 1.4517 (LEM 51)
43.30	Standard mechanical seal	Cr-steel / carbon / butadiene rubber		Cr Ni Mo-steel / carbon / Viton
75.11	Valve plate	PTFE		

Cut-away diagram LEM 26, LEM 51

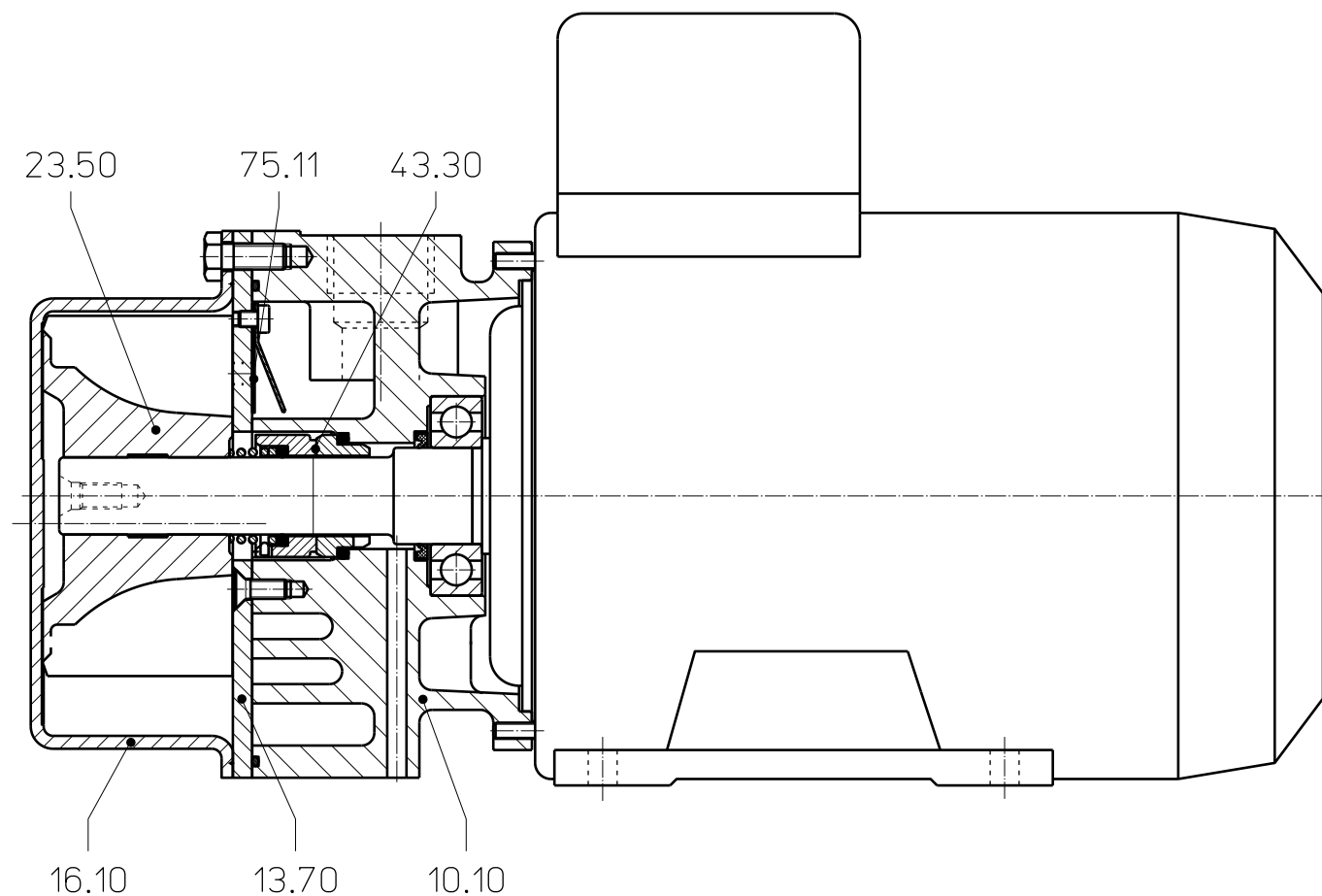

Make-up liquid consumption in [m³/h] dependent upon suction pressure, speed, drive type and temperature difference

Suction Pressure [mbar]		33					120					200					400				
Pump Type	Speed [rpm]	KB			FB	KB			FB	KB			FB	KB			FB				
		Temperature Difference [°C]				Temperature Difference [°C]				Temperature Difference [°C]				Temperature Difference [°C]							
		10	5	2		10	5	2		10	5	2		10	5	2					
LEM 26	2900	0.04	0.07	0.14	0.39	0.05	0.09	0.16	0.36	0.05	0.09	0.15	0.3	0.05	0.08	0.14	0.28				
	3500	0.06	0.10	0.18		0.07	0.11	0.19		0.07	0.11	0.18									
LEM 51	2900	0.07	0.13	0.23	0.48	0.09	0.15	0.24	0.42	0.09	0.14	0.23	0.36	0.09	0.14	0.22	0.34				
	3500	0.11	0.17	0.28		0.12	0.19	0.28		0.12	0.18	0.26									

FB = Total service liquid flow rate on once-through system

KB = Flow of make-up water when combined with partial recirculation liquid at a temperature of 10 °C, 5 °C, 2 °C, warmer than make-up water

Performance Characteristics LEM 26

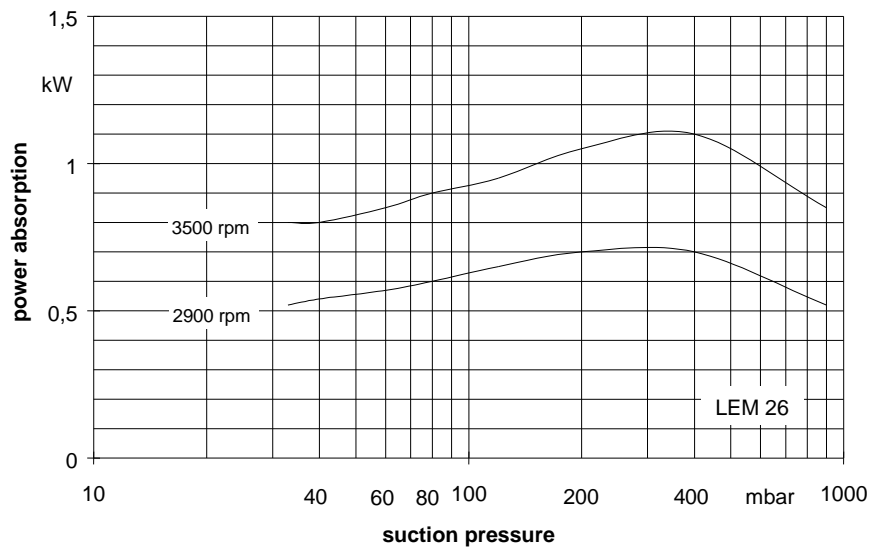
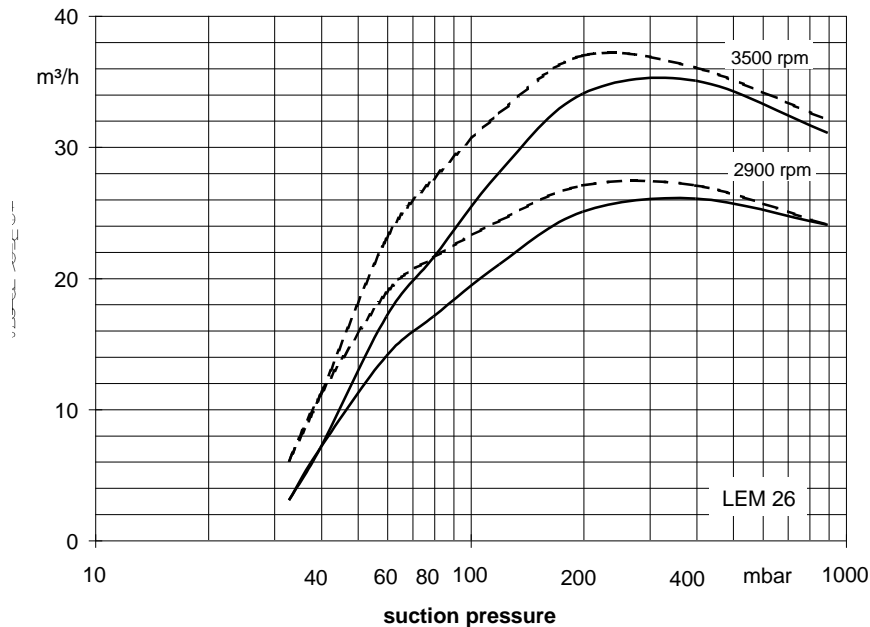

The operating data is valid under the following conditions:

- process media:
 - dry air: 20°C _____
 - steam saturated air: 20°C - - - - -
- service liquid:
 - water: 15°C

Pressure of gas to be evacuated: 1013 mbar (atmospheric pressure)

The suction volume is related to the suction pressure.

Tolerance on operating data is 10%.

The maximum consumption of make-up water occurs at the lowest suction pressure.

Performance Characteristics LEM 51

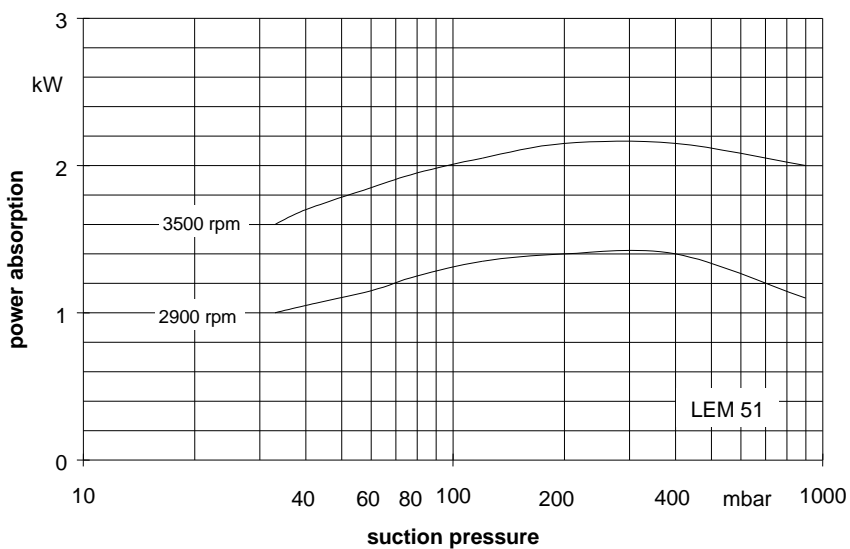
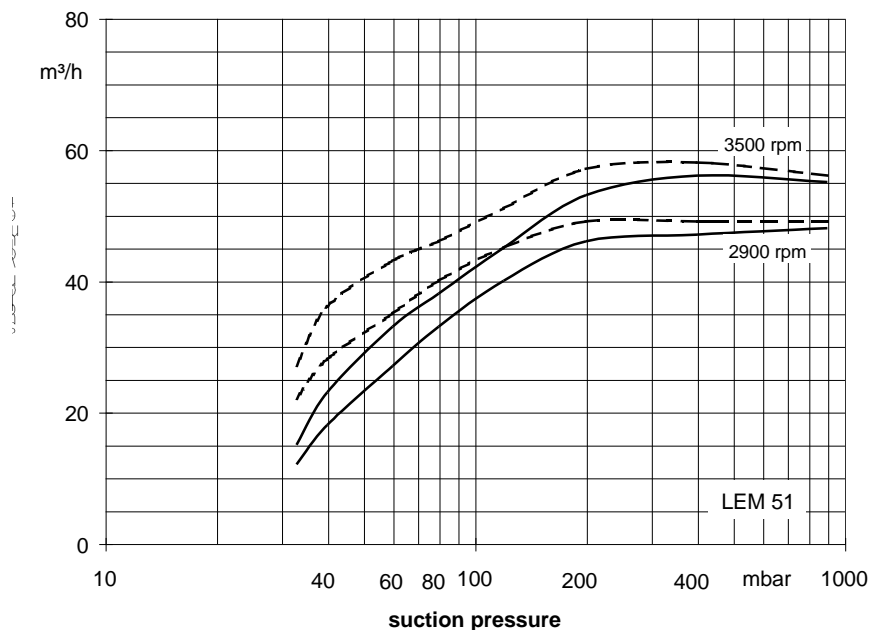

The operating data is valid under the following conditions:

- process media:
 - dry air: 20°C _____
 - steam saturated air: 20°C - - - - -
- service liquid:
 - water: 15°C

Pressure of gas to be evacuated: 1013 mbar (atmospheric pressure)

The suction volume is related to the suction pressure.

Tolerance on operating data is 10%.

The maximum consumption of make-up water occurs at the lowest suction pressure.

Dimensions LEM 26

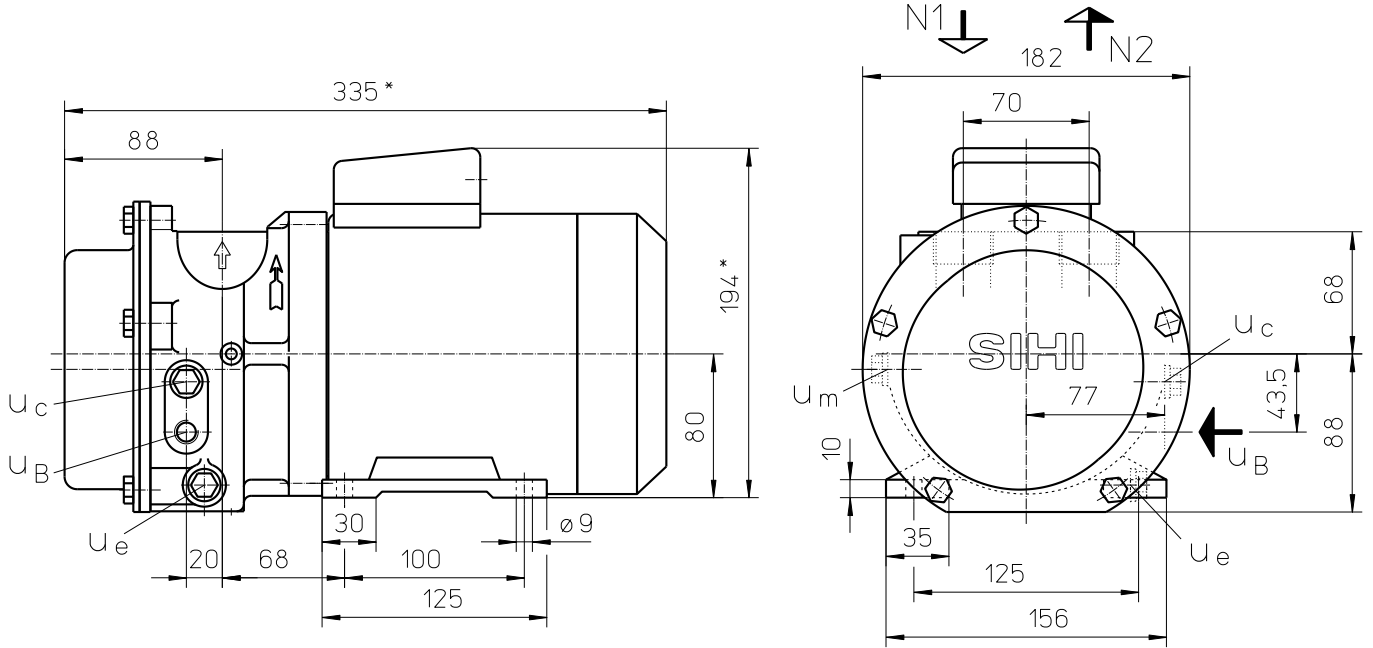

	electric motor IP 55		approx. weight [kg]	
	size	kW		
		50 Hz	60 Hz	
LEM 26	80	1.1	1.1	22

other motors on request

* dimension dependent upon motor supplier

N 1 = gas inlet G 1

N 2 = gas outlet G 1

u_B = connection for service liquid G ¼

u_C = connection for protection against cavitation G ¼

u_e = connection for drain G ¼

u_m = connection for pressure gauge G ¼

Dimensions LEM 51

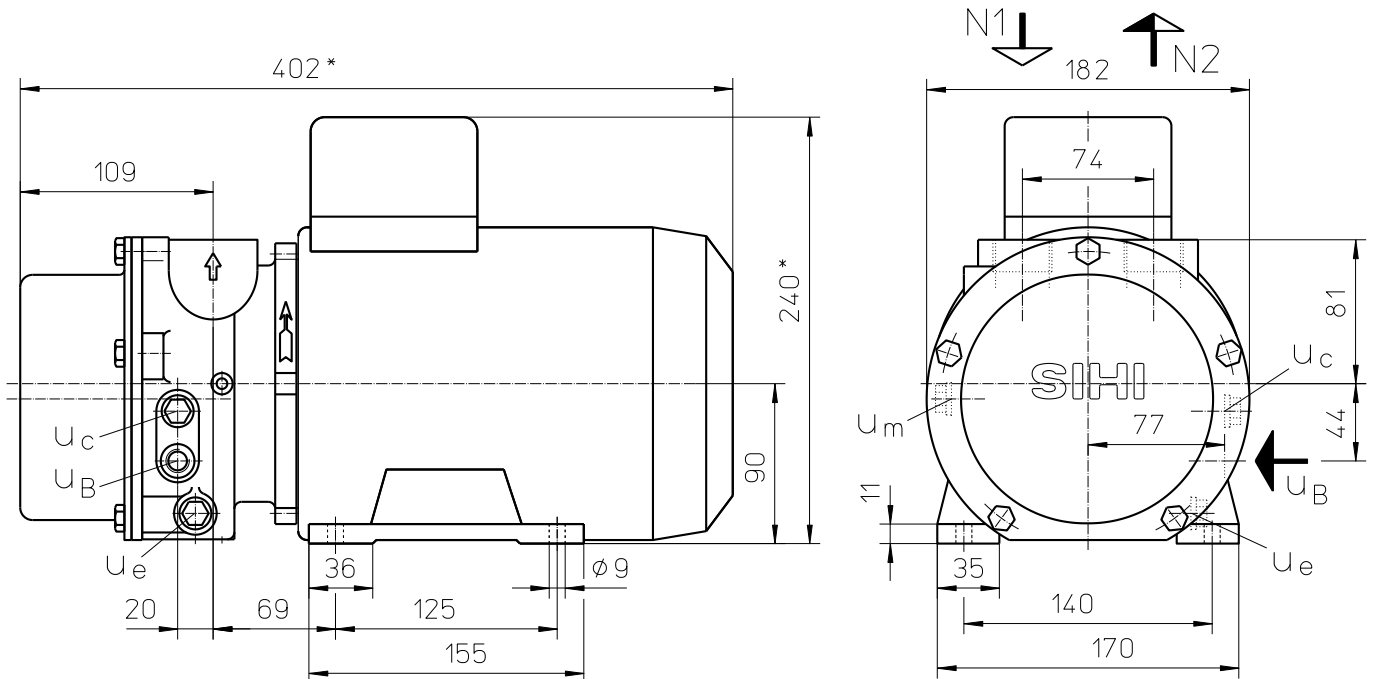

	electric motor IP 55		approx. weight [kg]	
	size	kW		
		50 Hz	60 Hz	
LEM 51	90 L	1.8	2.2	30 ... 32

other motors on request

* dimension dependent upon motor supplier

N 1 = gas inlet G 1

N 2 = gas outlet G 1

u_B = connection for service liquid G ¼

u_C = connection for protection against cavitation G ¼

u_e = connection for drain G ¼

u_m = connection for pressure gauge G ¼

Arrangement drawing LEM 26, LEM 51

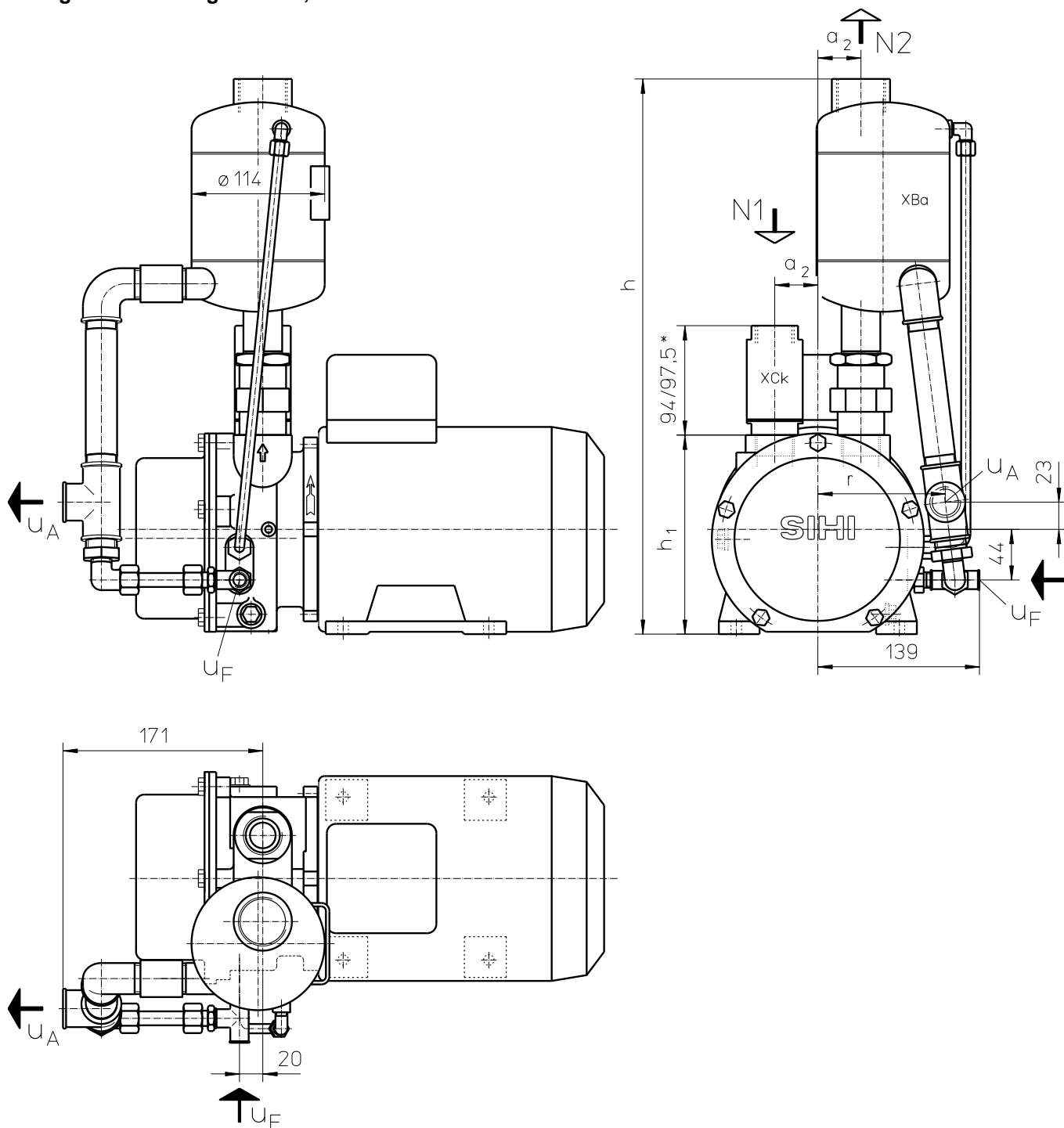

* stainless steel / brass

N 1 = gas inlet G 1

N 2 = gas outlet G 1¼

u_A = liquid overflow G ¾

u_F = connection for make-up liquid G ¼

	electric motor IP 55		a_2 [mm]	h [mm]	h_1 [mm]	r [mm]	approx. weight [kg]	
	size	50 Hz						60 Hz
LEM 26	80	1.1	1.1	35	394	148	105	28
LEM 51	90 L	1.8	2.2	37	477	171	109	36 ... 38

Data regarding the pump size - order hints

range + size	hydraulic + bearings	shaft seal	materials	casing sealing
	A• hydraulic A •Z two grease lubricated antifriction bearings arranged in the motor	AAE mechanical seal, o-rings butadiene rubber AA1 similar to AAE, but o-rings Viton	0A main parts out of cast iron 0K main parts out of cast iron, impeller in low alloyed steel 4B main parts out of stainless steel	7 O-rings, teflon cord
LEM 26	AZ	AAE, AA1	0K, 4B	7
LEM 51			0A, 4B	

Motor Selection

For our products we offer a lot of different motor types.
To identify the right motor please specify frequency, voltage and protection class.

Example of an Order:

LEMA 51 AZ AAE 0A 7 with 1.8 kW AC motor, 50 Hz, 230V Δ, IP55

Accessories LEM 26, LEM 51

Recommended accessories		Material execution	LEM 26	LEM 51
Top mounted liquid separator		Type / weight	XBa 244 / 2.8 kg	
Top mounted separator	1.4571	SIHI-Part No.	35 000 375	
service liquid pipework, standard execution	Steel, galvanised 1.4571	SIHI- Part No.	20 055 639 20 055 640	20 087 968 20 088 080
service liquid pipework, thermostatic control 24V	1.0254 + Brass 1.4571 + Brass	SIHI- Part No.	20 086 989 20 050 596	
Cavitation protection pipework	Steel, galvanised 1.4571	SIHI- Part No.	20 042 674 20 042 672	
Sterling SIHI – Gas ejector		Type / weight	GEV 25 A / 1.1 kg	GEV 50 A / 1.1 kg
at service liquid temperature 15 °C		Type / weight	GEV 25 A / 1.1 kg	GEV 50 A / 1.1 kg
Sterling SIHI – Non return ball valve		Size / weight	G 1 / 0.7 kg	
	Brass + Butadiene rubber	SIHI-Teil Nr.	20 044 637	
	Brass + Teflon		20 044 639	
	1.4571 + Teflon		20 072 807	

Any changes in the interest of the technical development are reserved.

Sterling SIHI GmbH

Lindenstraße 170, D-25524 Itzehoe, Germany
Telephone +49 (0) 48 21 / 7 71-01, Fax +49 (0) 48 21 / 7 71-274
www.flowserve-sihi.com