

Vacuum pump

LEM, LEL

LEM/LEL F 91/126/161

Capacity 24-78 m ³ /h	Pressure range 33-1013 mbar	Material Cast iron & Stainless steel
--	---------------------------------------	--

Description

A one stage liquid ring vacuum pump in OEM construction. Close coupled pump where the motor is mounted directly on the pump casing to take up as little space as possible when mounted on the system

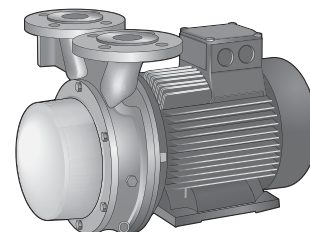

AT 6300

Range of application

Evacuation and pumping of dry gases and saturated steam. Typical industries are chemistry, pharmaceutical, food, plastic and rubber industry. Vacuum is used for distillation, drying, degassing, filling and boiling.

Design

The pump works according to the liquid ring principle. Fluid pumps are in some regards related with displacement pumps since the pump wheel is eccentrically located in the round pump body. When the wheel is rotating a fluid ring is created along the pump body's inner wall. In the cells (the space between the pump body's wings) inside the fluid ring rising part volumes (intake) and then decreasing volumes (outlet) will be created under one rotation.

Product key (example LEMA 26 AZ AA1 4B 7 1A)

Pos	Description	Code	Explanation
1-3	Pump model	LEM	Liquid ring vacuum pump
4	Construction	A,B	
5-7	Pump size	25-425	
8	Hydraulics	A,8	Threaded inlet/outlet
		C,9	Flanged inlet/outlet
9	Bearing	Z	Motor bearing
10-12	Sealing	AAE	Mechanical sealing SIHI FN EBP GG
		AA1	Mechanical sealing SIHI FN GBV GG
13-14	Material	0A	See table below
		0K	See table below
		4B	See table below
15	Gasket	0	Fluid sealing
		7	O-ring Teflon
16-17	Motor data	1A,1B, KW	Depending on motor size

Bara de vanligaste kombinationerna nämns ovan, för special kontakta Armatec

Vacuum pump

LEM, LEL

LEM/LEL F 91/126/161

Material combinations

Pos	OK
Vacuum casing	0.6025 cast iron
Guide disc	1.4301 Stainless steel
Cover	1.4301 stainless steel
Shaft	1.4571 acid-proof steel
Impeller	1.4308 stainless steel
Valve ball	polyamid A

Dimensions

Pu mp	Si ze	Effect [IE C] [kW]	N1 [flan ge]	N2 [flan ge]	N1 [thre ad]	N2 [thre ad]	e [m]	h1 [m]	m 2 [m]	m 4 [m]	n2 [m]	n3 [m]	W 1 [m]
LE		2,2											
M	90	[50Hz	DN	DN	G 1	G 1			12	n/	14	20	39
91	L]	40	40	1/4	1/4	91	90	5	a	0	0	9
LE		3,3											
M	10	[60Hz	DN	DN	G 1	G 1		10	14	n/	16	22	42
91	0L]	40	40	1/4	1/4	91	0	0	a	0	0	0

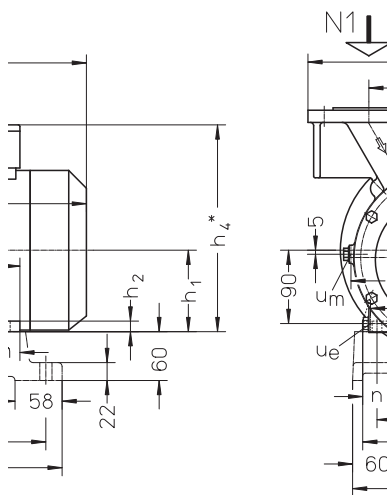

LEM 91-126

Connections

Connections	Designation 91
UB	Service fluid G 1/4
Ue	Drainage G 1/4
Uc	Cavitation protection G 1/4
Um	Pressure sensor G 1/4

Service fluid in m³/h

Pressure mbar	in	33	120	200	400
LEM 91		0,66	0,62	0,6	0,54

Total service fluid by installation where the fluid is directed straight in to the drain.
For other installations ask Armatec

Rätten till ändringar utan föregående meddelande förbehålls.
Armatec ansvarar inte för eventuella tryckfel eller missförstånd.
Dokumentet får kopieras endast i sin helhet.