

CEH

Sizes 1201 ... 6108, 1202/5 ... 6108/5, 1202/7 ... 6107/7

Technical data

Capacity:	max. 35 m ³ /h
Delivery head:	max. 354 m
Speed:	max. 1800 1/min
Temperature:	max. 120 °C max. 180 °C for high temperature design (higher temperatures upon request)
Casing pressure:	PN 40
Shaft sealing:	Stuffing box or mechanical seal
Flange connections:	DIN 2501 / PN 40
Direction of rotation:	anti-clockwise (when seen from the drive end)



Application

The SIHI CEH pump is a self-priming side channel pump capable of handling gas along with the medium and operates at a low noise level.

The CEH pumps are used for problem-free pumping of clean liquids at unfavourable suction side conditions. They are also very suitable for positive suction heads below 0.5m.

The different material possibilities with uniform dimensions and performance characteristics as well as the standard exchangeable components, make the CEH particularly recommendable for applications in the pharmaceutical, chemical or petrochemical market as well as in the plastic or oil industry. Because of its low NPSH and positive suction head the CEH is very suitable for the pumping of liquefied gasses and liquids under vapour pressure like condensate, refrigerant, boiler feed water or LPG.

The pumps of the CEH /7 series have a retaining stage to avoid the dry running by controlling the liquid level in the pump. This design is especially developed for the handling of liquids under vapour pressure or when pumping from underground tanks. The series CEH /5 are used for bottom off-loading of liquids under vapour pressure.

Design

Pumps of the series CEH have a segmental type construction with open vane wheel impellers. The construction of the CEH pump is a so-called centrifugal combined system. This combination pump is suited with a centrifugal stage in serial connection before the side channel stages to obtain a more favourable NPSH.

The program comprises 6 sizes each with 1-8 stages. The existing material design allows an optimum rating for the respectively desired performance range and the pumping medium.

Pumps of the series CEH /7 are equal to the CEH series but equipped with a retaining stage. This program comprises 6 sizes with 2-7 stages. The series CEH /5 have also 6 sizes but with 2-8 stages.

The applied hydraulic components are from our Modular Side Channel system (interchangeability of parts).

Construction

Casing pressure

Maximum 40 bar from -40 °C up to +120 °C.
Maximum 32 bar from +120 °C up to +180 °C.
Pressure stages for temperature as per DIN EN 1333.

Please observe

Technical rules and safety regulations.
Casing pressure = inlet pressure + delivery head at minimum pump capacity.

Position of branches

Axial suction branch, discharge branch points radially upwards.

Flanges

The flanges correspond to DIN EN 1092-2 / PN 40.
Flange design as per DIN 2512 with groove or drilled according to ANSI 150 or 300 lbs is basically possible.

Bearing

One grease lubricated ball bearing according to DIN 625 and one liquid surrounded sleeve bearing (design A). The ball bearing is greased for life.

Direction of rotation

Anti-clockwise, when looking from the drive end.

Shaft sealing

The shaft can be sealed by a stuffing box or a mechanical seal conform DIN EN 12756. The shaft sealing is also available in a design suitable for heating or cooling of the stuffing box or the mechanical seal.

Double mechanical seal (back-to-back as well as tandem) or a quench design with throttle bush are available upon request. The CEH can also be supplied with a magnetic coupling (for information see the separate catalogue).

Material design

Cast iron and ductile iron

Pos.	Components	Material design					
		0A	0B	0F	1A	1B	1F
1060	Suction casing	EN-GJL-250			EN-GJS-400-18-LT		
1070	Discharge casing	EN-GJL-250			EN-GJS-400-18-LT		
1080 1090 1140 1141	Intermediate piece	EN-GJL-250			EN-GJS-400-18-LT		
2100	Shaft	X 20 Cr 13					
2310	Impeller	EN-GJL-250					
2350	Vane wheel impeller	CuZn40Al2	G-X 3 CrNiMoCuN 26 6 3 3	PAEK	CuZn40Al2	G-X 3 CrNiMoCuN 26 6 3 3	PAEK
3500	Bearing housing	EN-GJL-250					
4410	Mechanical seal casing	EN-GJL-250			EN-GJS-400-18-LT		
4510	Stuffing box casing	EN-GJL-250			EN-GJS-400-18-LT		
0241	Bearing bush	CY 10 C / Carbon Antimony*					

* Bearing bush in carbon antimony is used only in the high temperature design. This high temperature design is also provided with cup springs and a cooled stuffing box or cooled mechanical seal.

Stainless steel

Pos.	Components	Material design	
		4B	4F
1060	Suction casing	G-X 6 CrNiMo 18 10	
1070	Discharge casing	G-X 6 CrNiMo 18 10	
1080 1090 1140 1141	Intermediate piece	G-X 6 CrNiMo 18 10	
2100	Shaft	X 5 CrNiMo 17 12 2	
2310	Impeller	G-X 3 CrNiMoNb 18 10	
2350	Vane wheel impeller	G-X 3 CrNiMoCuN 26 6 3 3	PAEK
3500	Bearing housing	EN-GJL-250 coated	
4410	Mechanical seal casing	G-X 6 CrNiMo 18 10	
0241	Bearing bush	CY 10 C / Carbon Antimony *	

* Bearing bush in carbon antimony is used only in the high temperature design. This high temperature design is also provided with cup springs and a cooled stuffing box or cooled mechanical seal.

Casing seal

The casing seal can be sealed with a liquid compound or soft Teflon.

Drive

By lelectrica motor, type of construction IM B3.
For LPG, EExe or Eex d(e) motors are available.

Sectional drawing and parts list

CEH with stuffing box

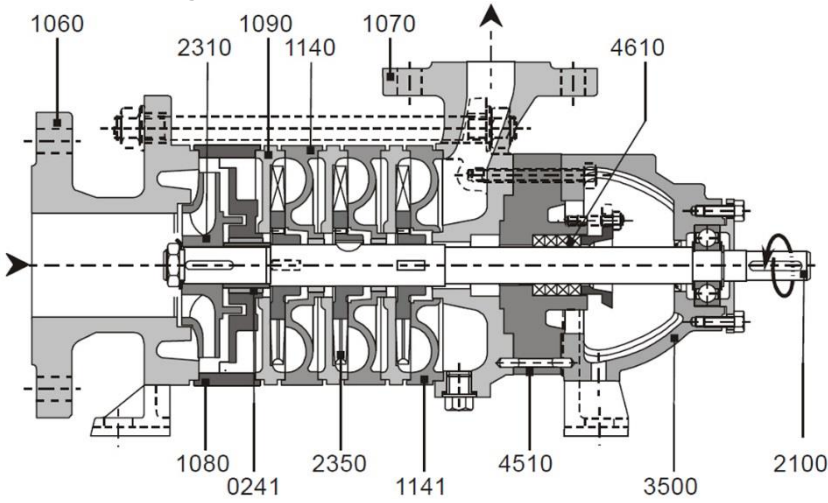

- 0241 Bearing bush
- 1060 Suction casing
- 1070 Discharge casing
- 1080 Intermediate piece
- 1081 Retaining stage
- 1090 Suction intermediate piece
- 1140 Discharge intermediate piece
- 1141 Discharge intermediate piece
- 2100 Shaft
- 2310 Impeller
- 2350 Vane wheel impeller
- 3500 Bearing housing
- 4330 Mechanical seal
- 4410 Mechanical seal casing
- 4420 Cooling insert
- 4510 Stuffing box casing
- 4610 Stuffing box

CEH with mechanical seal

Unbalanced as well as balanced mechanical seals are available.

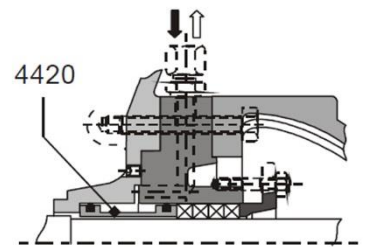
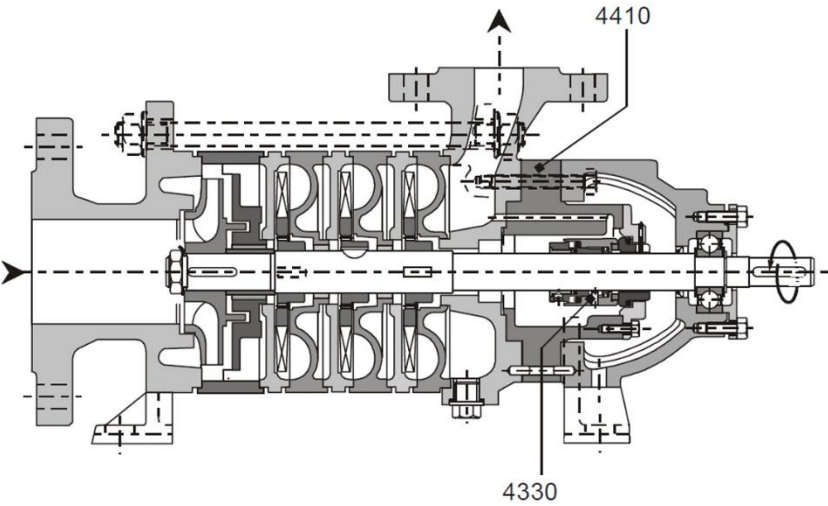

Cooled stuffing box

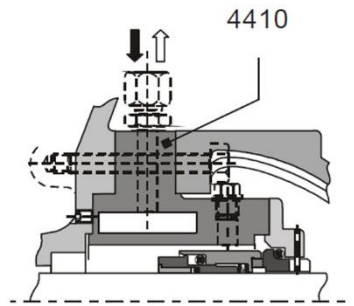

Cooled mechanical seal

CEH /7 with retaining stage

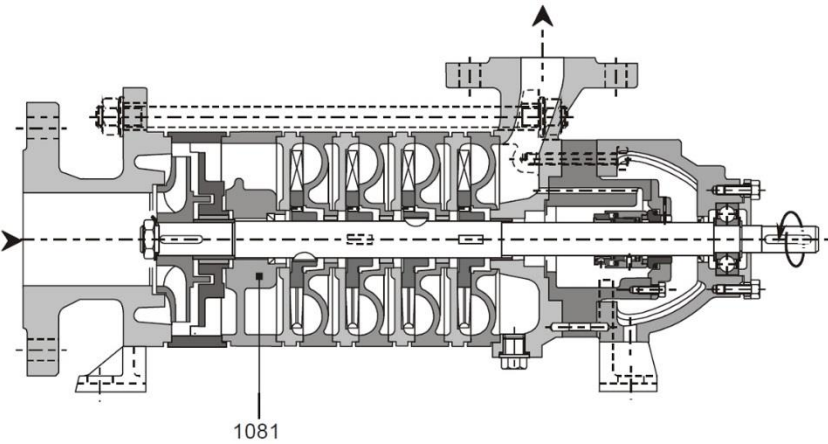

Performance range

General conditions

Liquid: Water
 Density: 1 kg/dm³
 Viscosity: 1 cSt
 Temperature: 20 °C
 Atmospheric pressure: 1013 mbar

Characteristic tolerances

Capacity ± 5% - Delivery head ± 5% - Power + 10%

For designs with a mechanical seal or a casing seal of soft Teflon, the tolerance for the delivery head is extended by 2% each.

Measuring standard

According to ISO 5198.

--- = Maximum for CEH /7 (with retaining stage)
 - · - = Minimum for CEH /5 (e.g. LPG handling), CEH/7

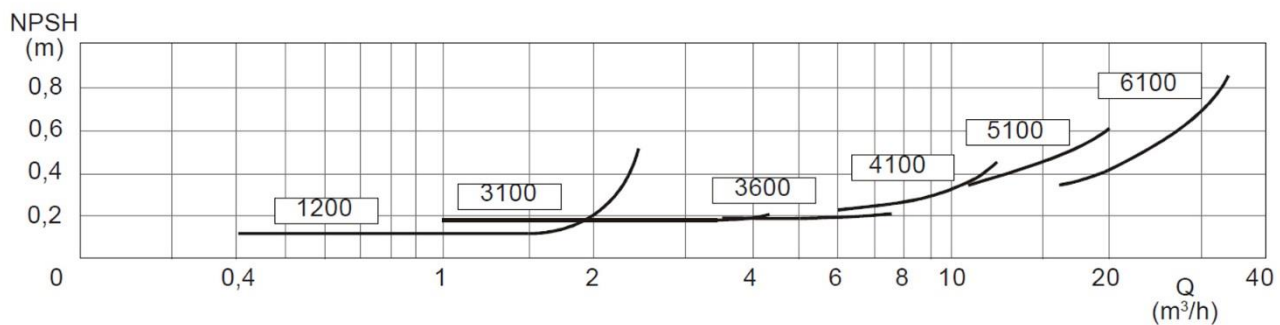
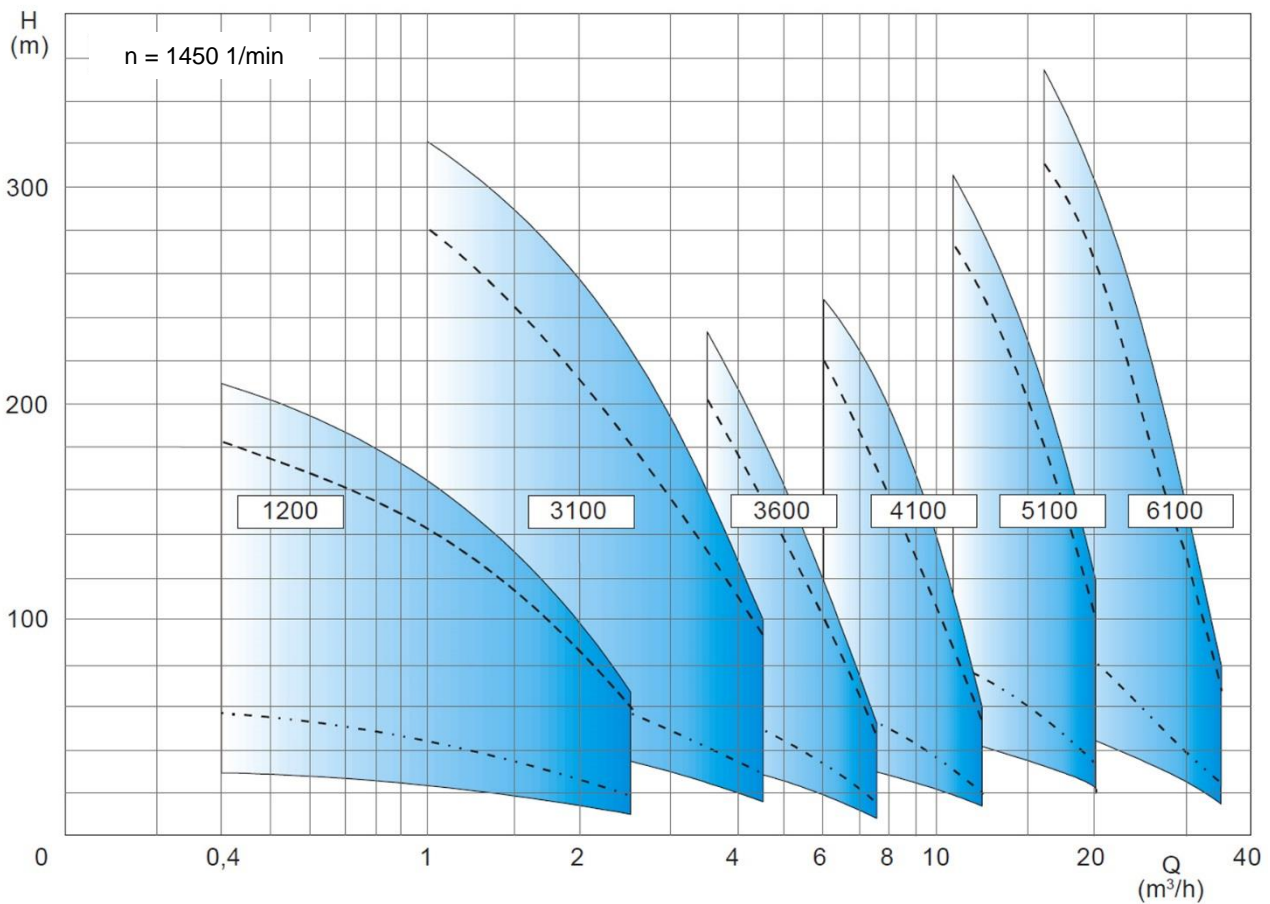

The NPSH curve is suitable for liquids without gas. When using a liquid containing gas (e.g. water 20°C) a safety margin of 1 m has to be added.

Dimension chart, pump set drawing and performance curves

CEH 1200 and CEH 1200/5

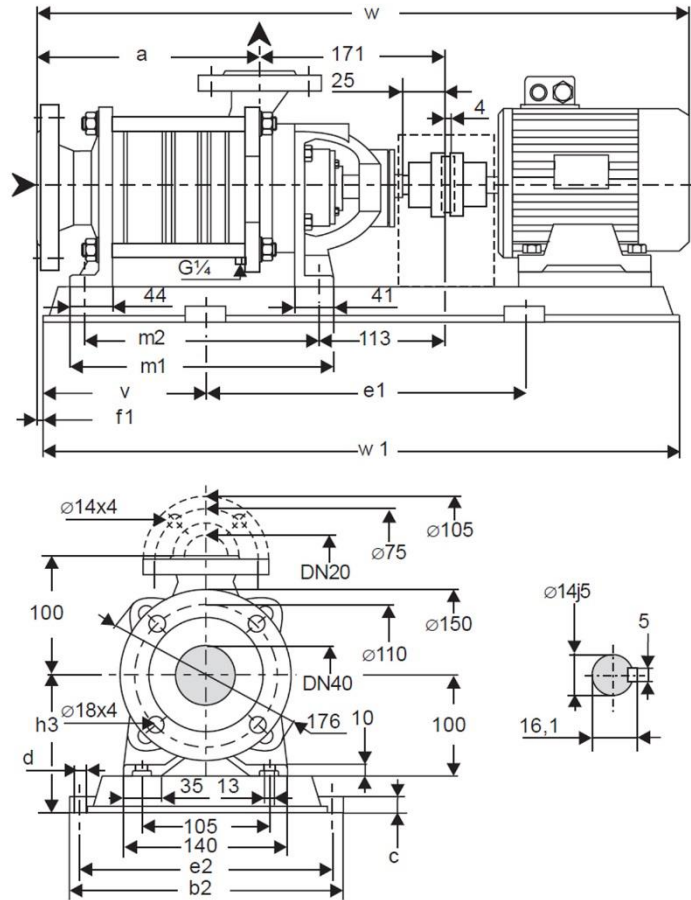
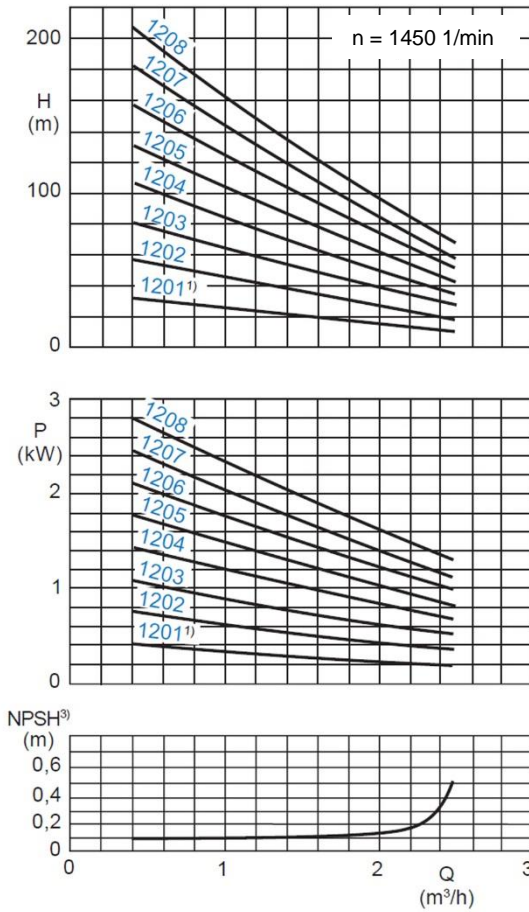

Values are valid for water at 1 kg/dm³ and Viscosity at 1 cSt.

Capacity ± 5% - Delivery head ± 5% - Power + 10%

For designs with a mechanical seal or a casing seal of soft Teflon, the tolerance for the delivery head is extended by 2% each.

Pump size	Motor		Base plate	Coupling		Weight [kg]		Dimensions [mm]															
	kW	kW ²⁾		size	B	BDS ²⁾	Pump	set	a	b2	c	d	e1	e2	v	f1	h3	m1	m2	w*	w1		
1201	0.37	1)	71	P007	68	1)	18	39	195	317	20	15	350	285	110	-9	135	238	204	609	570		
	0.55		80	P008				45		297			265	120	140		643			640			
1202	0.55	0.55	80	P008	68	76	20	47	229	297	20	15	400	265	120	-9	140	272	238	677	640		
	0.75	0.75	80					56		330			25	19	480		290			125	165	735	730
	1.1	1.0	90S					52		300			25	19	420		260			115	711	650	
1203	0.75	0.75	80	P241	68	76	22	58	263	300	25	19	480	290	125	-9	165	306	272	769	730		
	1.1	1.0	90S					62		330			25	19	480		290			125	711	650	
	1.5	1.35	90L					60		330			25	19	480		290			125	769	730	
1204	1.1	1.0	90S	P241	68	76	24	60	297	330	25	19	480	290	125	-9	165	340	306	803	730		
	1.5	1.35	90L					64		360			25	19	540		320			140	844	820	
	2.2	2.0	100L					75		360			25	19	540		320			140	844	820	
1205	1.1	1.0	90S	P272	68	76	26	66	331	360	25	19	540	320	140	-9	165	374	340	837	820		
	1.5	1.35	90L					70		360			25	19	540		320			140	837	820	
	2.2	2.0	100L					77		360			25	19	540		320			140	878	820	
1206	1.5	1.35	90L	P272	68	76	28	72	365	360	25	15	540	320	140	-9	165	408	374	871	820		
	2.2	2.0	100L					84		361			25	15	600		325			160	912	920	
	3.0	2.5	100L					85		361			25	15	600		325			160	912	920	
1207	1.5	1.35	90L	P015	68	76	30	74	399	361	25	15	600	325	160	-9	150	442	408	905	920		
	2.2	2.0	100L					86		361			25	15	600		325			160	946	920	
	3.0	2.5	100L					87		361			25	15	600		325			160	946	920	
1208	2.2	2.0	100L	P015	80	88	32	88	433	361	25	15	600	325	160	-9	150	476	442	980	920		
	3.0	2.5	100L					89		361			25	15	600		325			160	980	920	

* Dimensions depend upon the motor brand. 1) Not for design CEH /5, 2) for EExe II T3 motors, 3) A safety margin of 1 m has to be added when using a liquid containing gas. The weight for stainless steel will be approximately 6% higher.

Dimension chart, pump set drawing and performance curves

CEH 3100 and CEH 3100/5

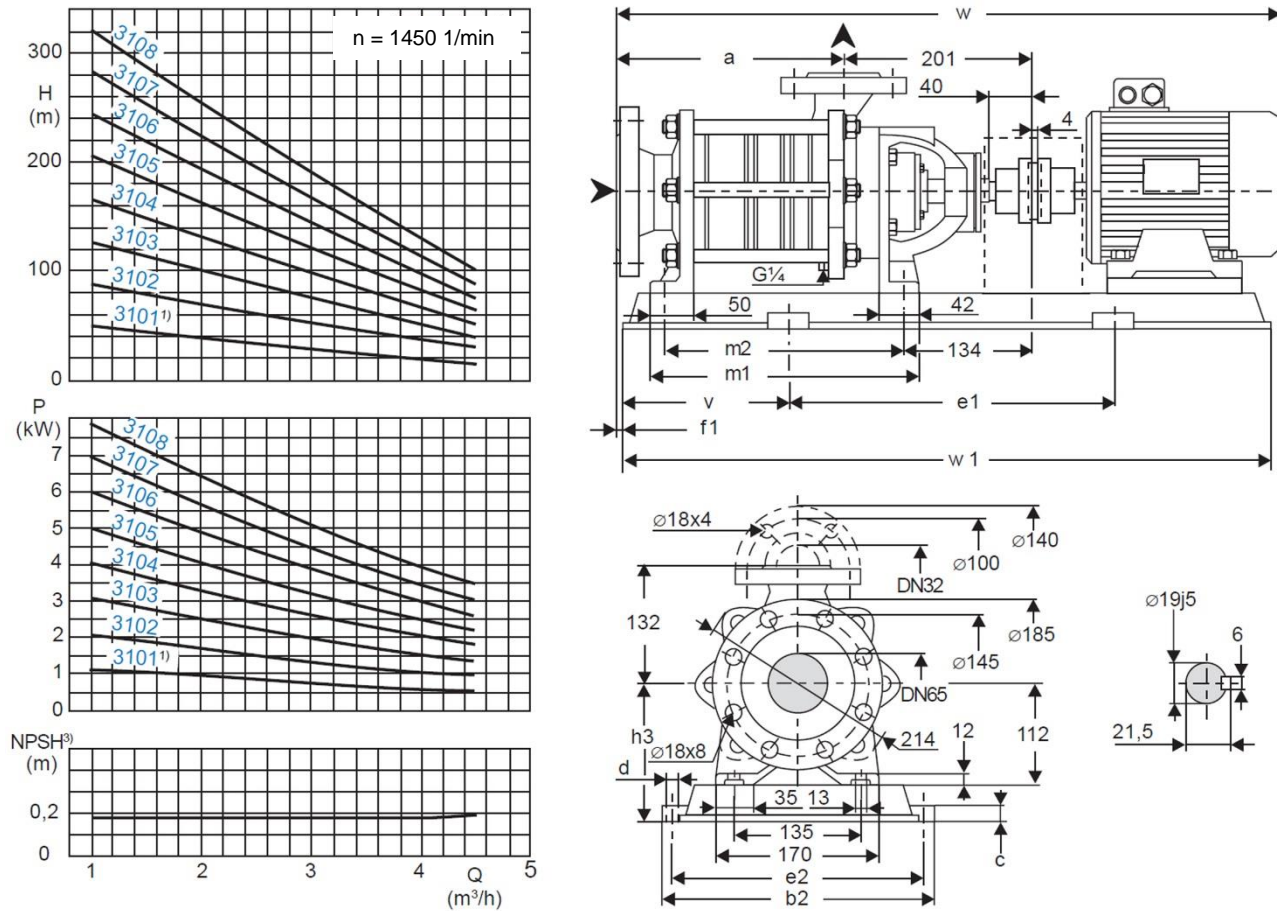

Values are valid for water at 1 kg/dm³ and Viscosity at 1 cSt.

Capacity ± 5% - Delivery head ± 5% - Power + 10%

For designs with a mechanical seal or a casing seal of soft Teflon, the tolerance for the delivery head is extended by 2% each.

Pump size	Motor		Base plate	Coupling		Weight [kg]		Dimensions [mm]																		
	kW	kW ²⁾		size	B	BDS ²⁾	Pump	Set	a	b2	c	d	e1	e2	v	f1	h3	m1	m2	w*	w1					
3101	0.75	1)	80	P008	68	1)	31	60	213	297	20	15	400	265	120	-13	152	261	227	691	640					
	1.1		90S	P241				67	330	25	19	480	290	125	177		749			730						
3102	1.1	1.0	90S	P241	68	78	34	72	253	330	25	19	480	290	125	-13	177	301	267	789	730					
	1.5	1.35	90L					74												830	820					
	2.2	2.0	100L					81												360	540	320	140	830	820	
3103	2.2	2.0	100L	P272	80	88	38	89	293	360	25	19	540	320	140	-13	177	341	307	870	820					
	3.0	2.5	100L					90												93	162	910	820			
3104	2.2	2.0	100L	P272	80	88	42	93	333	360	25	19	540	320	140	-13	177	381	347	910	820					
	3.0	2.5	100L					94												361	15	600	325	160	931	920
	4.0	3.6	112M					117												15	600	325	160	931	920	
3105	3.0	2.5	100L	P015	80	88	45	102	373	361	25	15	600	325	160	-13	162	421	387	950	920					
	4.0	3.6	112M					120												700	200	192	1047	1100		
	5.5	5.0	132S					158												700	200	192	1047	1100		
3106	4.0	3.6	112M	P015	80	88	48	123	413	361	25	15	600	325	160	-13	162	461	427	1011	920					
	5.5	5.0	132S					161												700	325	200	192	1087	1100	
	7.5	6.8	132M					171												700	325	200	192	1113	1100	
3107	4.0	3.6	112M	P017	80	88	52	143	453	361	25	15	700	325	200	-13	172	501	467	1051	1100					
	5.5	5.0	132S					165												700	325	200	192	1127	1100	
	7.5	6.8	132M					205												700	325	200	192	1153	1100	
3108	4.0	3.6	112M	P017	95	103	55	198	493	361	25	15	700	325	200	-13	192	541	507	1167	1100					
	5.5	5.0	132S					208												840	490	215	240	1193	1100	
	7.5	6.8	132M					253												540	30	24	840	490	215	240

* Dimensions depend upon the motor brand. ¹⁾ Not for design CEH /5, ²⁾ for EExe II T3 motors, ³⁾ A safety margin of 1 m has to be added when using a liquid containing gas. The weight for stainless steel will be approximately 6% higher.

Dimension chart, pump set drawing and performance curves

CEH 3600 and CEH 3600/5

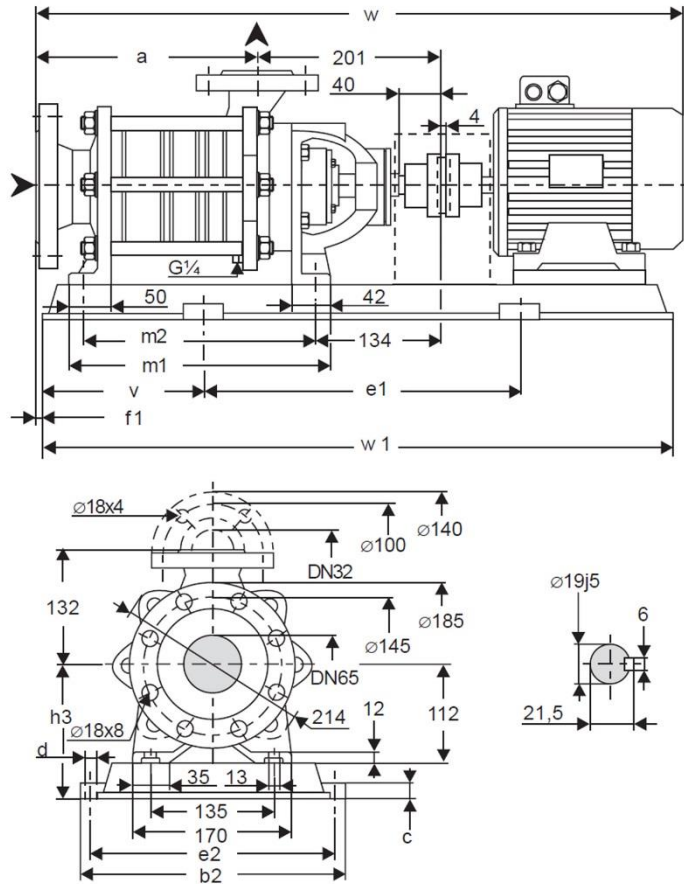
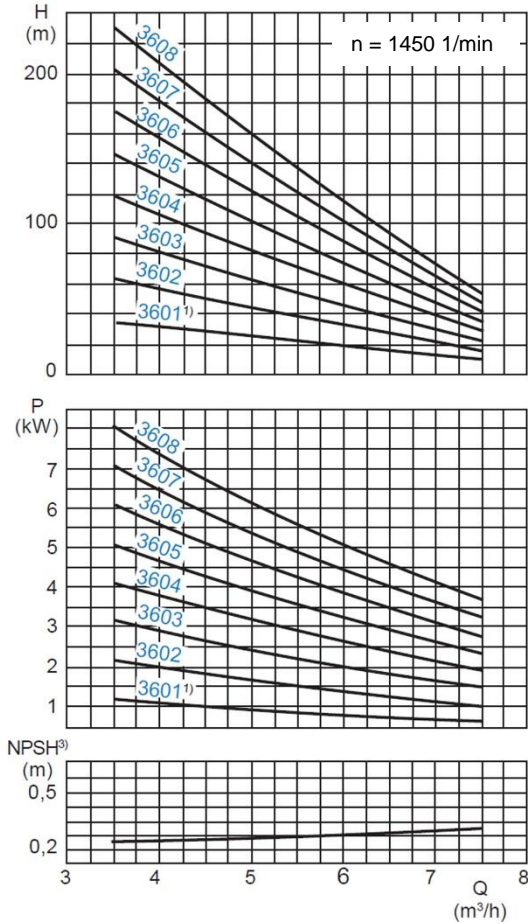

Values are valid for water at 1 kg/dm³ and Viscosity at 1 cSt.

Capacity ± 5% - Delivery head ± 5% - Power + 10%

For designs with a mechanical seal or a casing seal of soft Teflon, the tolerance for the delivery head is extended by 2% each.

Pump size	Motor		Base plate	Coupling		Weight [kg]		Dimensions [mm]																			
	kW	kW ²⁾		size	B	BDS ²⁾	Pump	Set	a	b2	c	d	e1	e2	v	f1	h3	m1	m2	w*	w1						
3601	0.75	1)	80	P008	68	76	31	55	213	297	20	15	400	265	120	-13	152	261	227	691	640						
	1.1		90S	67				330												25	19	480	290	125	177	749	730
	1.5		90L	74				330												25	19	480	290	125	177	789	730
3602	1.5	1.35	90L	P241	68	76	34	74	253	330	25	19	480	290	125	-13	177	301	267	789	730						
	2.2	2.0	100L	P272	80	88	89	360												25	140	830	820				
3603	2.2	2.0	100L	P272	80	88	38	89	293	360	25	19	540	320	140	-13	177	341	307	870	820						
	3.0	2.5	100L					101												162		182	910				
	4.0	3.6	112M					119												162		182	931				
3604	3.0	2.5	100L	P272	80	88	42	105	333	361	25	15	600	325	160	-13	177	381	347	910	820						
	4.0	3.6	112M					117												162		182	931				
	5.5	5.0	132S					152												162		182	1007				
3605	3.0	2.5	100L	P015	80	88	45	102	373	361	25	15	600	325	160	-13	162	421	387	950	920						
	4.0	3.6	112M					120												162		182	971				
	5.5	5.0	132S					171												162		182	1047				
3606	4.0	3.6	112M	P015	80	88	48	123	413	361	25	15	600	325	160	-13	162	461	427	1011	920						
	5.5	5.0	132S					161												162		182	1087				
	7.5	6.8	132M					171												162		182	1113				
3607	5.5	5.0	132S	P017	95	103	52	165	453	361	25	15	700	325	200	-13	192	501	467	1127	1100						
	7.5	6.8	132M					168												162		182	1153				
3608	5.5	5.0	132S	P017	95	103	55	161	493	361	25	15	700	325	200	-13	192	541	507	1167	1100						
	7.5	6.8	132M					171												162		182	1193				
	11.0	10.0	160M					P436												254		540	30	24	840	490	215

* Dimensions depend upon the motor brand. ¹⁾ Not for design CEH /5, ²⁾ for EExe II T3 motors, ³⁾ A safety margin of 1 m has to be added when using a liquid containing gas. The weight for stainless steel will be approximately 6% higher.

Dimension chart, pump set drawing and performance curves

CEH 4100 and CEH 4100/5

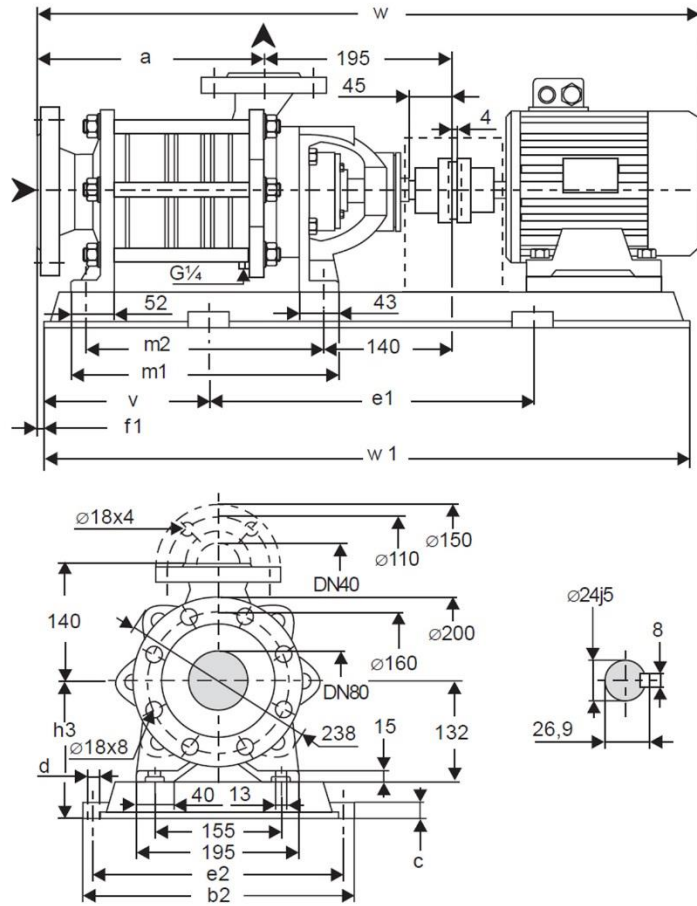
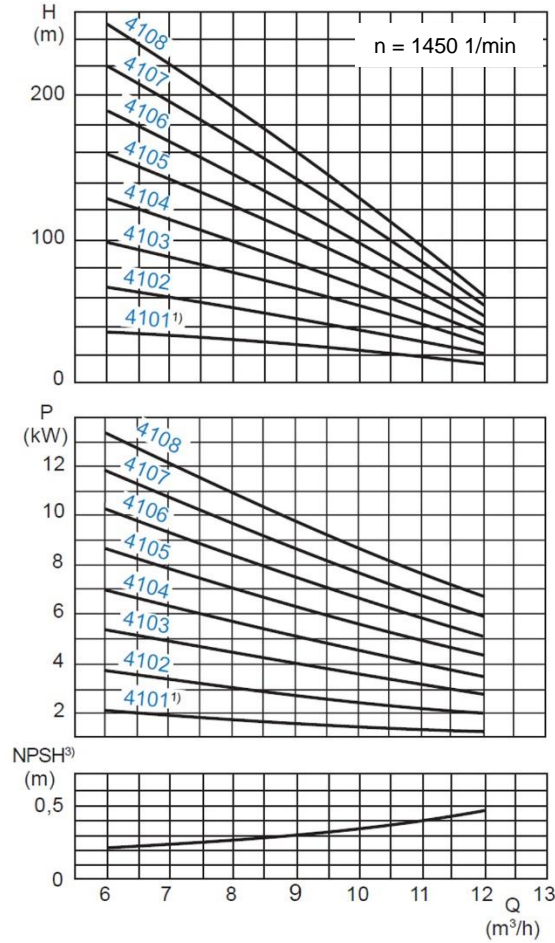

Values are valid for water at 1 kg/dm³ and Viscosity at 1 cSt.

Capacity ± 5% - Delivery head ± 5% - Power + 10%

For designs with a mechanical seal or a casing seal of soft Teflon, the tolerance for the delivery head is extended by 2% each.

Pump size	Motor		Base plate	Coupling		Weight [kg]		Dimensions [mm]													
	kW	kW ²⁾		size	B	BDS ²⁾	Pump	Set	a	b2	c	d	e1	e2	v	f1	h3	m1	m2	w*	w1
4101	1.5	1)	90L	P241	68	1)	41	81	268	330	25	19	480	290	125	-23	197	294	260	798	730
	2.2		100L	P272	80			95					540	320	140					839	820
4102	2.2	2.0	100L	P272	80	88	47	98	323	360	25	19	540	320	140	-23	197	349	315	894	820
	3.0	2.5	100L					110												128	
4103	4.0	3.6	112M	P015	80	88	53	128	378	361	25	15	600	325	160	-23	182	404	370	970	920
	5.5	5.0	132S	P017	95			179					700	200	192		1046			1100	
4104	5.5	5.0	132S	P017	95	103	59	172	433	361	25	15	700	325	200	-23	192	459	425	1101	1100
	7.5	6.8	132M					182												1127	
4105	5.5	5.0	132S	P017	95	103	65	178	488	361	25	15	700	325	200	-23	192	514	480	1156	1100
	7.5	6.8	132M					181												1182	
4106	11.0	10.0	160M	P385	95	103	70	264	543	490	30	24	740	440	200	-23	240	569	535	1274	1140
	7.5	6.8	132M	P385				196					540	840	490		215			212	1237
4107	11.0	10.0	160M	P436	95	103	76	269	598	540	30	24	840	490	215	-23	240	624	590	1329	1270
	7.5	6.8	132M	202				275					212	1292	1384						
4108	15.0	13.5	160L	P487	110	118	82	349	653	610	35	28	940	550	240	-23	260	679	645	1446	1420
	11.0	10.0	160M	P487	95	103		281					240	260	1439		1501				
	15.0	13.5	160L		110	118		355												1501	1420

* Dimensions depend upon the motor brand. ¹⁾ Not for design CEH /5, ²⁾ for EExe II T3 motors, ³⁾ A safety margin of 1 m has to be added when using a liquid containing gas. The weight for stainless steel will be approximately 6% higher.

Dimension chart, pump set drawing and performance curves

CEH 5100 and CEH 5100/5

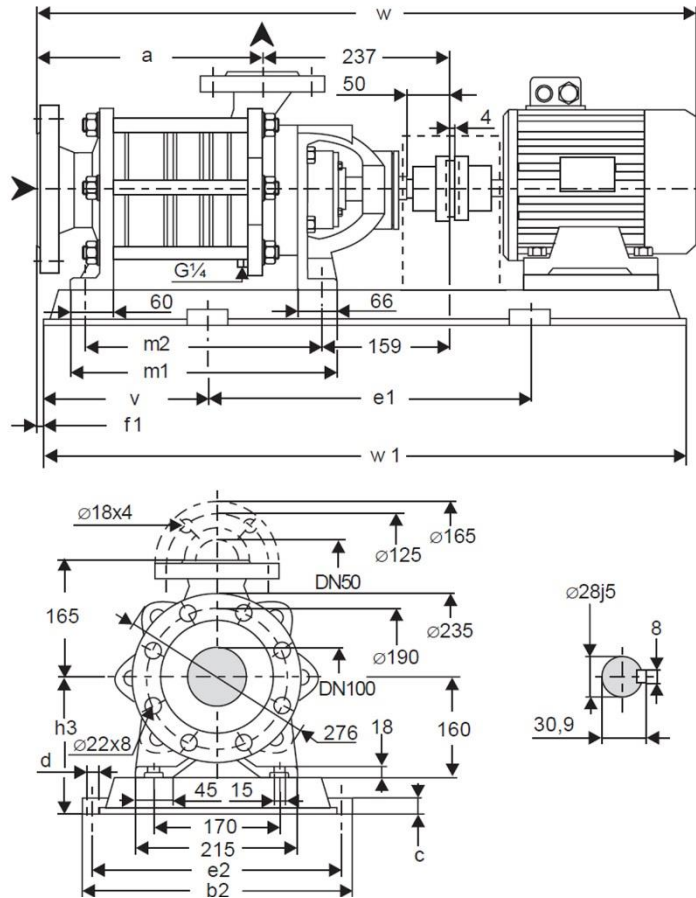
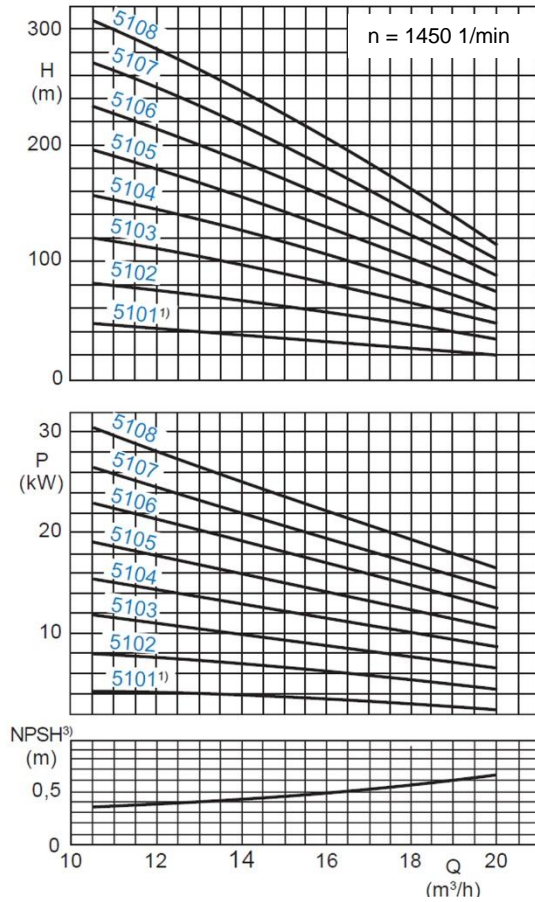

Values are valid for water at 1 kg/dm³ and Viscosity at 1 cSt.

Capacity ± 5% - Delivery head ± 5% - Power + 10%

For designs with a mechanical seal or a casing seal of soft Teflon, the tolerance for the delivery head is extended by 2% each.

Pump size	Motor			Base plate	Coupling		Weight [kg] Pump	Set	Dimensions [mm]												
	kW	kW ²⁾	size		B	BDS ²⁾			a	b2	c	d	e1	e2	v	f1	h3	m1	m2	w*	w1
5101	3.0	1)	100L	P272	80	1)	60	123	305	360	25	19	540	320	140	225	353	315	918	820	
	4.0		112M					162											939		
	5.5		132S					170											1015	920	
5102	5.5	5.0	132S	P017	95	103	70	183	380	361	25	15	700	325	200	-28	210	428	390	1090	1100
	7.5		132M					193												1116	
	11.0		160M					269												1208	1140
5103	7.5	6.8	132M	P385	95	103	80	196	455	361	25	15	700	325	200	-28	220	503	465	1191	1100
	11.0		160M					279												1283	1140
	15.0		160L					353												1345	1270
5104	11.0	10.0	160M	P436	95	103	90	289	530	540	30	24	840	490	215	-28	240	578	540	1358	1270
	15.0		160L					363												1420	
5105	15.0	13.5	160L	P487	110	118	101	374	605	610	35	28	940	550	240	-28	260	653	615	1495	1420
	18.5		180M					395												1557	
	22.0		180L					415												1570	1420
5106	15.0	13.5	160L	P487	110	118	111	384	680	610	35	28	940	550	240	-28	260	728	690	1570	1420
	18.5		180M					423												1632	1620
	22.0		180L					425												1690	
	30.0		200L					506												1690	
5107	18.5	15.0	180M	P538	110	118	121	415	755	660	35	28	1060	600	280	-28	280	803	765	1707	1620
	22.0		180L					435												1765	
	30.0		200L					516												1782	1620
5108	22.0	17.5	180L	P539	125	135	132	446	830	660	35	28	1060	600	280	-28	280	878	840	1782	1620
	30.0		200L					527												1840	1800

* Dimensions depend upon the motor brand. 1) Not for design CEH /5, 2) for EExe II T3 motors, 3) A safety margin of 1 m has to be added when using a liquid containing gas. The weight for stainless steel will be approximately 6% higher.

Dimension chart, pump set drawing and performance curves

CEH 6100 and CEH 6100/5

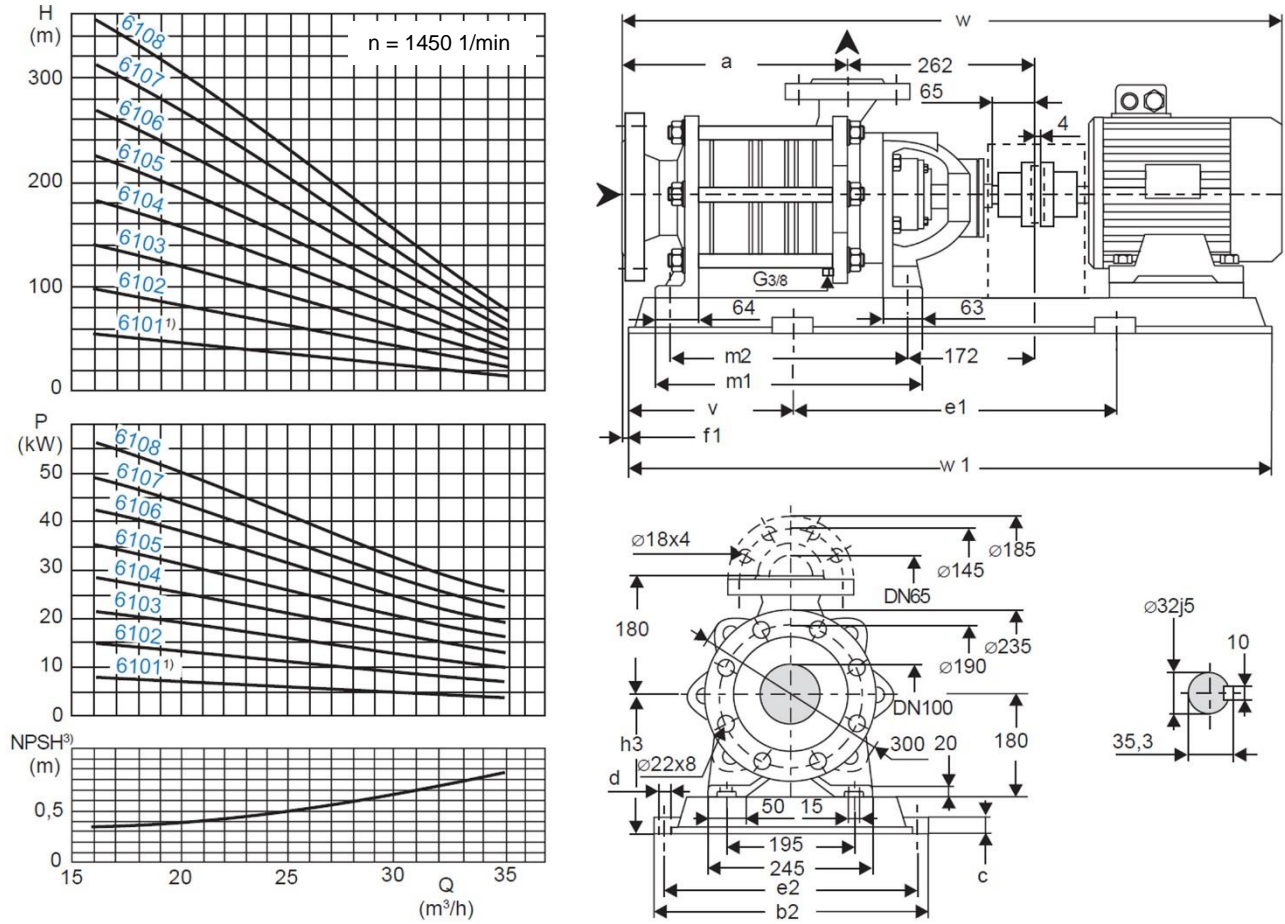

Values are valid for water at 1 kg/dm³ and Viscosity at 1 cSt.

Capacity ± 5% - Delivery head ± 5% - Power + 10%

For designs with a mechanical seal or a casing seal of soft Teflon, the tolerance for the delivery head is extended by 2% each.

Pump size	Motor		Base plate	Coupling		Weight [kg]		Dimensions [mm]													
	kW	kW ²⁾		size	B	BDS ²⁾	Pump	Set	a	b2	c	d	e1	e2	v	f1	h3	m1	m2	w*	w1
6101	5.5	1)	132S	P017	95	1)	80	206	338	361	25	15	700	325	200	-35	240	391	353	1073	1100
	7.5		132M					203												1099	
6102	11.0	10.0	160M	P385	95	103	92	291	428	490	30	24	740	440	200	-35	260	481	443	1281	1140
	15.0	13.5	160L	P436	110	118		365					840	490	215					1343	
6103	18.5	15.0	180M	P487	110	118	105	404	518	610	35	28	940	550	240	-35	280	571	533	1495	1420
	22.0	17.5	180L		125	135		419					1060	600	280					1643	
6104	22.0	17.5	180L	P487	125	135	117	431	608	610	35	28	940	550	240	-35	280	661	623	1585	1420
	30.0	24.0	200L	P538				512					1060	600	280		300			1643	
6105	30.0	24.0	200L	P538	125	135	130	525	698	660	35	28	1060	600	280	-35	300	751	713	1733	1620
	37.0	30.0	225S		140	152		594					1060	600	280		325			1798	
6106	30.0	24.0	200L	P538	125	135	130	537	660	35	28	1060	600	280	-35	300	841	803	1823	1620	
	37.0	30.0	225S		140	152		594					1060	600		280			325		1798
6107	30.0	24.0	200L	S389	125	135	155	550	878	730	40	28	1200	490	300	-35	300	931	893	1913	1800
	37.0	30.0	225S	S609	140	152		619					1200	670	310		325			1978	
6108	37.0	30.0	225S	14211	140	152	167	532	968	740	40	28	1300	690	350	-35	345	1021	983	2003	2000
	45.0	36.0	225M					630							1200		670			310	
6108	55.0	44.0	250M	14212	160	-	167	701	968	740	40	28	1300	690	400	-35	370	1021	983	2125	2100

* Dimensions depend upon the motor brand. 1) Not for design CEH /5, 2) for EExe II T3 motors, 3) A safety margin of 1 m has to be added when using a liquid containing gas. The weight for stainless steel will be approximately 6% higher.

Dimension chart, pump set drawing and performance curves

CEH 1200/7 (with retaining stage)

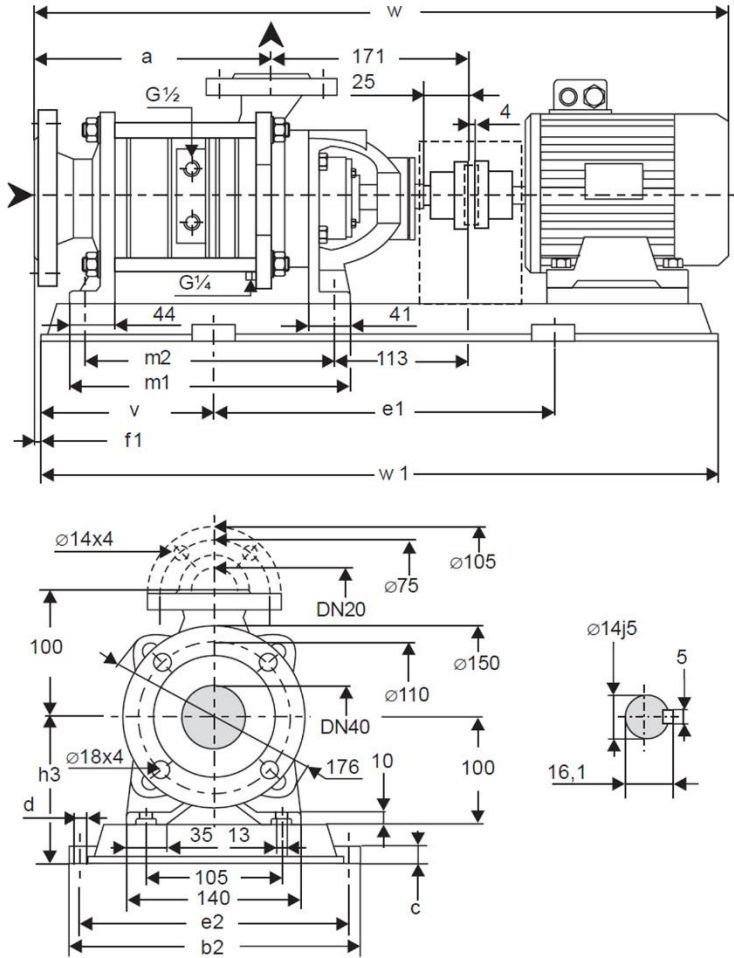
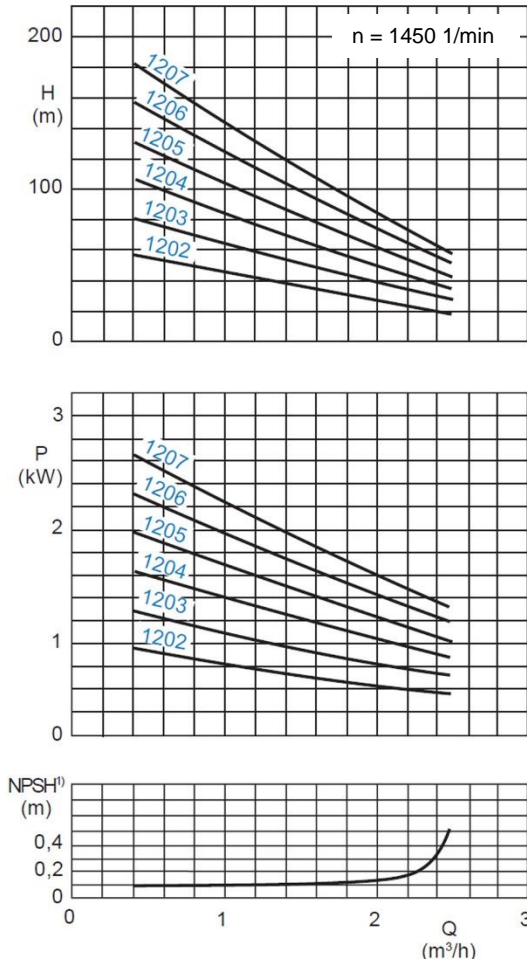

Values are valid for water at 1 kg/dm³ and Viscosity at 1 cSt.

Capacity ± 5% - Delivery head ± 5% - Power + 10%

For designs with a mechanical seal or a casing seal of soft Teflon, the tolerance for the delivery head is extended by 2% each.

Pump size	Motor		Base plate	Coupling BDS	Weight [kg]		Dimensions [mm]												
	kW	size			Pump	Set	a	b2	c	d	e1	e2	v	f1	h3	m1	m2	w*	w1
1202/7	0.55	80	P210	76	22	52	263	300	25	19	420	260	115	-9	165	306	272	709	650
	0.75	80				53													
1203/7	0.75	80	P241	76	24	54	297	330	25	19	480	290	125	-9	165	340	306	743	730
	1.1	90S				64												796	
1204/7	1.1	90S	P272	76	26	70	331	360	25	19	540	320	140	-9	165	374	340	930	820
	1.5	90L				71													
1205/7	1.5	90L	P272	76	28	73	365	360	25	19	540	320	140	-9	165	408	374	864	820
	2.0	100L				84												922	
1206/7	1.5	90L	P015	76	30	69	399	361	25	15	600	325	160	-9	150	442	408	898	920
	2.0	100L				86												956	
1207/7	1.5	90L	P015	76	32	71	433	361	25	15	600	325	160	-9	150	476	442	932	920
	2.0	100L				91												990	

* Dimensions depend upon the motor brand

¹) A safety margin of 1 m has to be added when using a liquid containing gas.

Dimension chart, pump set drawing and performance curves

CEH 3100/7 (with retaining stage)

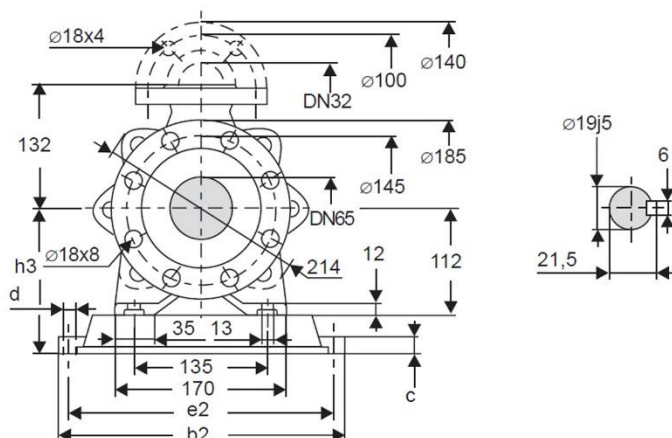
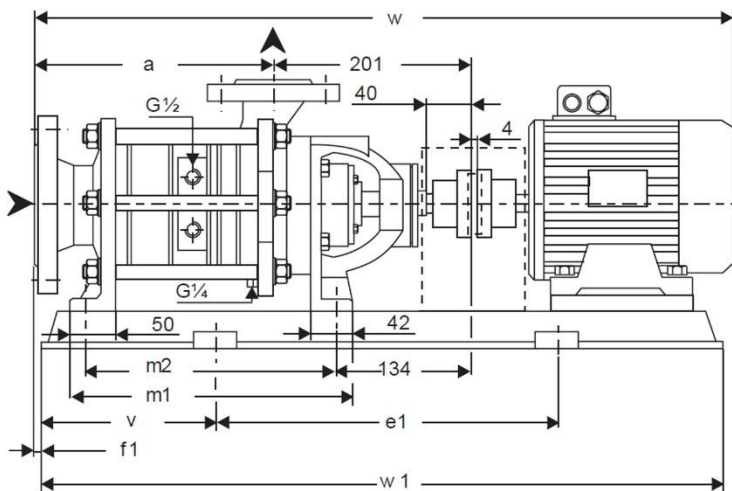
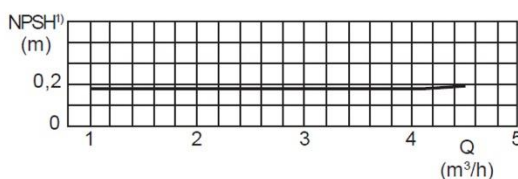
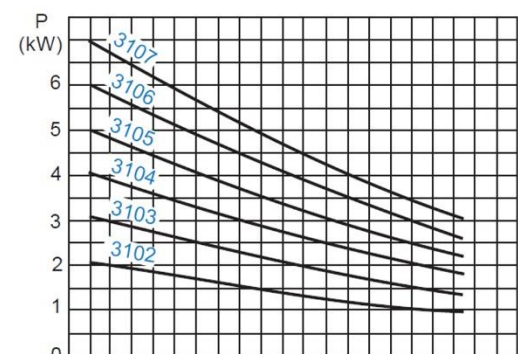
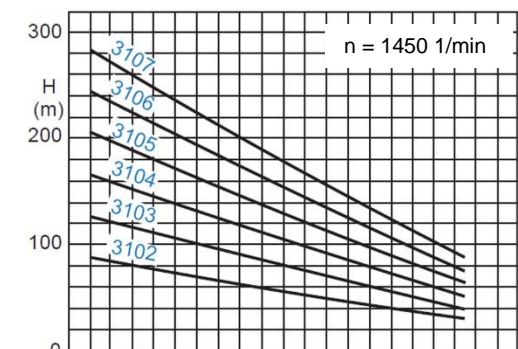

Values are valid for water at 1 kg/dm³ and Viscosity at 1 cSt.

Capacity ± 5% - Delivery head ± 5% - Power + 10%

For designs with a mechanical seal or a casing seal of soft Teflon, the tolerance for the delivery head is extended by 2% each.

Pump size	Motor		Base plate	Coupling BDS	Weight [kg]		Dimensions [mm]													
	kW	size			Pump	Set	a	b2	c	d	e1	e2	v	f1	h3	m1	m2	w*	w1	
3102/7	1.5	90L	P272	76	38	87	293	360	25	19	540	320	140	-13	177	341	307	822	820	
	2.0	100L		88		100												880		
3103/7	2.0	100L	P272	88	42	104	333	360	25	19	540	320	140	-13	177	381	347	920	820	
	2.5	100L				106														
3104/7	2.5	100L	P015	88	45	101	373	361	25	15	600	325	160	-13	162	421	387	960	920	
	3.6	112M				107												966		
3105/7	2.5	100L	P015	88	48	107	413	361	25	15	600	325	160	-13	162	461	427	1000	920	
	3.6	112M				110												1006		
3106/7	3.6	112M	P017	88	52	117	453	361	25	15	700	325	200	-13	172	501	467	1046	1100	
	5.0	132S		103		151									192			1142		
3107/7	3.6	112M	P017	88	55	120	493	361	25	15	700	325	200	-13	172	541	507	1086	1100	
	5.0	132S		103		154									192			1182		

* Dimensions depend upon the motor brand

¹⁾ A safety margin of 1 m has to be added when using a liquid containing gas.

Dimension chart, pump set drawing and performance curves

CEH 3600/7 (with retaining stage)

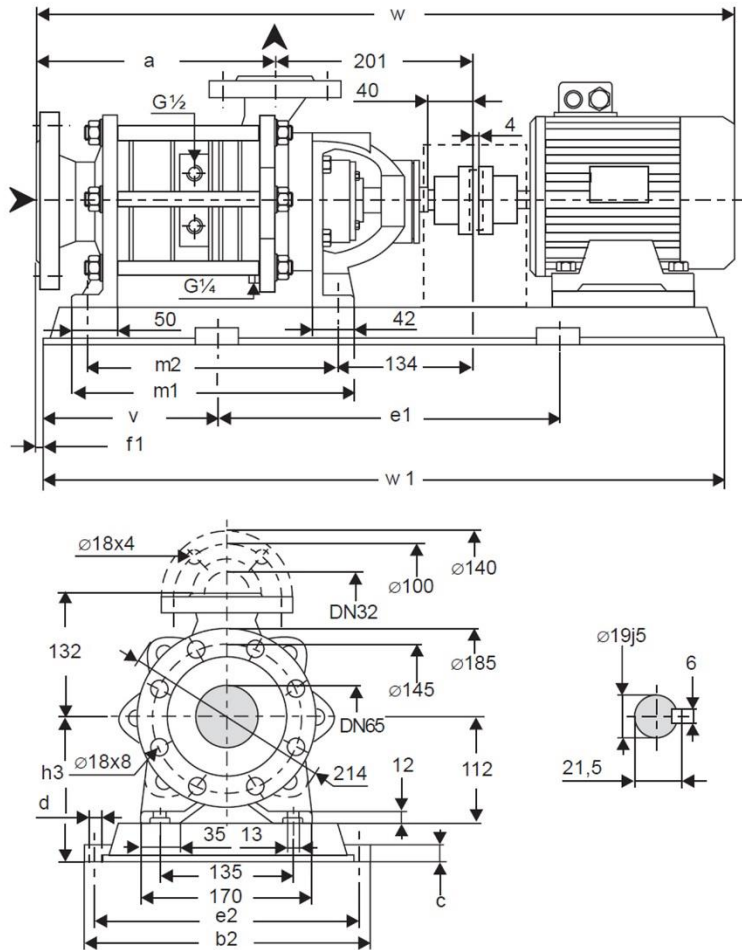
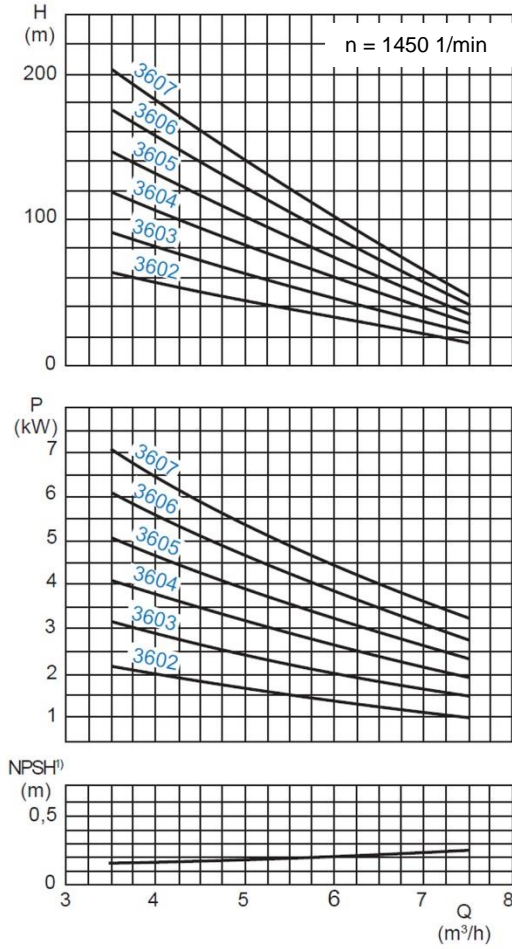

Values are valid for water at 1 kg/dm³ and Viscosity at 1 cSt.

Capacity ± 5% - Delivery head ± 5% - Power + 10%

For designs with a mechanical seal or a casing seal of soft Teflon, the tolerance for the delivery head is extended by 2% each.

Pump size	Motor		Base plate	Coupling BDS	Weight [kg]		Dimensions [mm]													
	kW	size			Pump	Set	a	b2	c	d	e1	e2	v	f1	h3	m1	m2	w*	w1	
3602/7	1.5	90L	P272	76	38	87	293	360	25	19	540	320	140	-13	177	341	307	822	820	
	2.0	100L		88		100												880		
3603/7	2.0	100L	P272	88	42	104	333	360	25	19	540	320	140	-13	177	381	347	920	820	
	2.5	100L		106		920														
3604/7	2.5	100L	P015	88	45	101	373	361	25	15	600	325	160	-13	162	421	387	960	920	
	3.6	112M		107		966														
3605/7	2.5	100L	P015	88	48	107	413	361	25	15	600	325	160	-13	162	461	427	1000	920	
	3.6	112M		110		1006														
3606/7	3.6	112M	P017	88	52	117	453	361	25	15	700	325	200	-13	172	501	467	1046	1100	
	5.0	132S		103		151									1142					
3607/7	3.6	112M	P017	88	55	120	493	361	25	15	700	325	200	-13	172	541	507	1086	1100	
	5.0	132S		103		154									1182					

* Dimensions depend upon the motor brand

1) A safety margin of 1 m has to be added when using a liquid containing gas.

Dimension chart, pump set drawing and performance curves

CEH 4100/7 (with retaining stage)

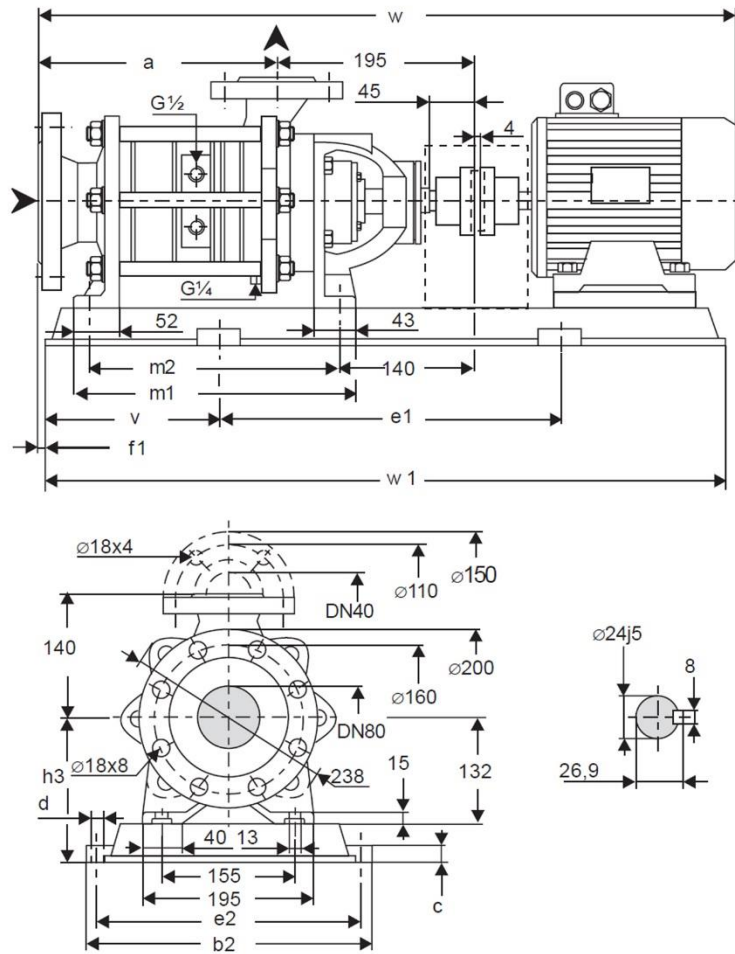
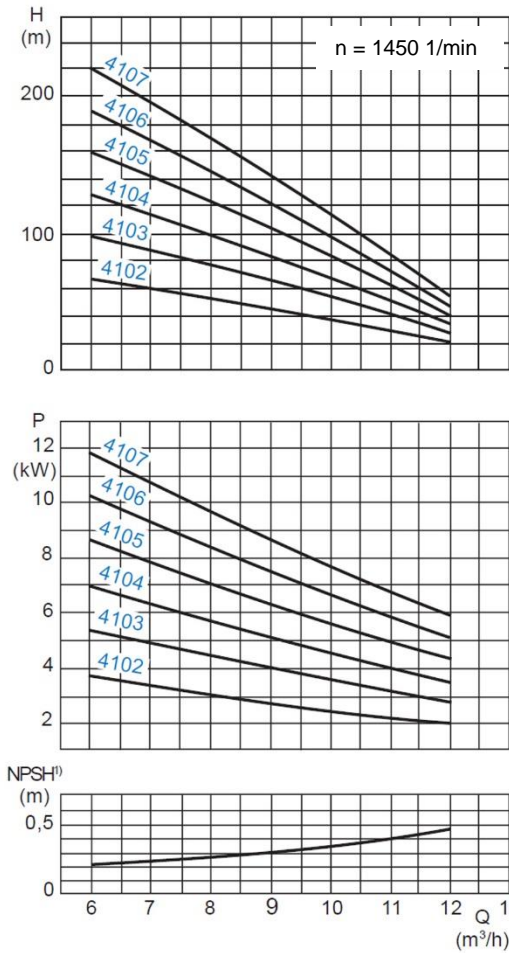

Values are valid for water at 1 kg/dm³ and Viscosity at 1 cSt.

Capacity $\pm 5\%$ - Delivery head $\pm 5\%$ - Power + 10%

For designs with a mechanical seal or a casing seal of soft Teflon, the tolerance for the delivery head is extended by 2% each.

Pump size	Motor		Base plate	Coupling BDS	Weight [kg]	Dimensions [mm]													
	kW	size				Pump	Set	a	b2	c	d	e1	e2	v	f1	h3	m1	m2	w*
4102/7	2.5	100L	P015	88	53	112	378	361	25	15	600	325	160	-23	182	404	370	959	920
	3.6	112M				115												965	
4103/7	3.6	112M	P015	88	59	121	433	361	25	15	600	325	160	-23	182	459	425	1020	920
	5.0	132S				158												1116	
4104/7	3.6	112M	P017	88	65	130	488	361	25	15	700	325	200	-23	192	514	480	1075	1100
	5.0	132S				164												1171	
4105/7	5.0	132S	P385	103	70	172	543	490	30	24	740	440	200	-23	212	569	535	1226	1140
	6.8	132M				232												1237	
4106/7	6.8	132M	P436	103	76	248	598	540	30	24	840	490	215	-23	212	624	590	1292	1270
	10.0	160M				278												1379	
4107/7	6.8	132M	P436	103	82	230	653	540	30	24	840	490	215	-23	212	679	645	1347	1270
	10.0	160M				296												1434	

* Dimensions depend upon the motor brand

¹⁾ A safety margin of 1 m has to be added when using a liquid containing gas.

Dimension chart, pump set drawing and performance curves

CEH 5100/7 (with retaining stage)

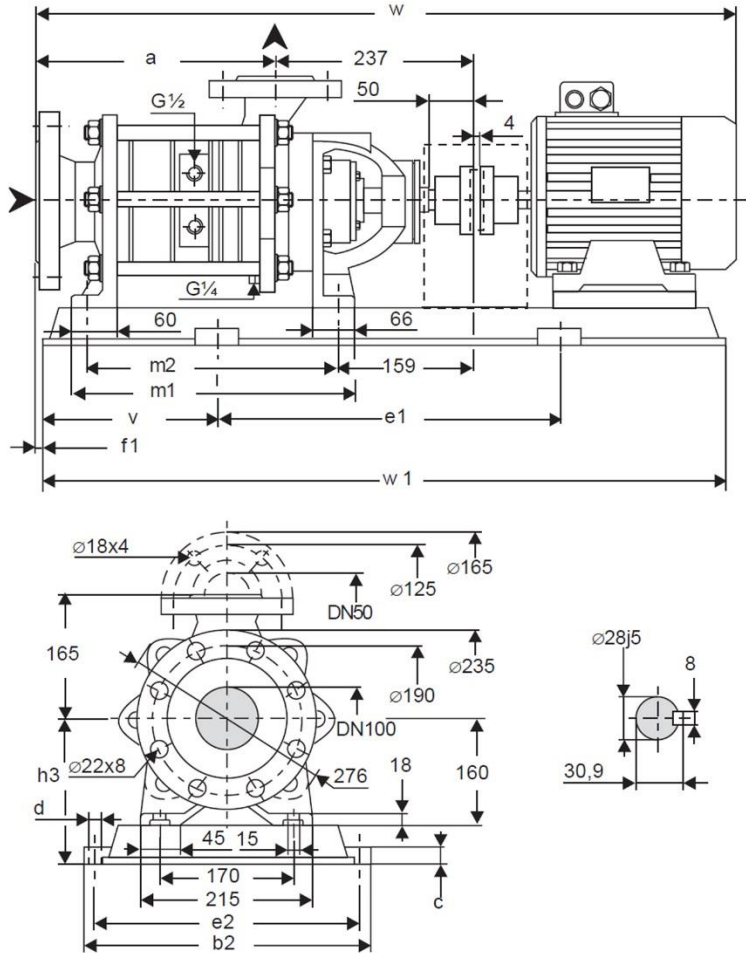
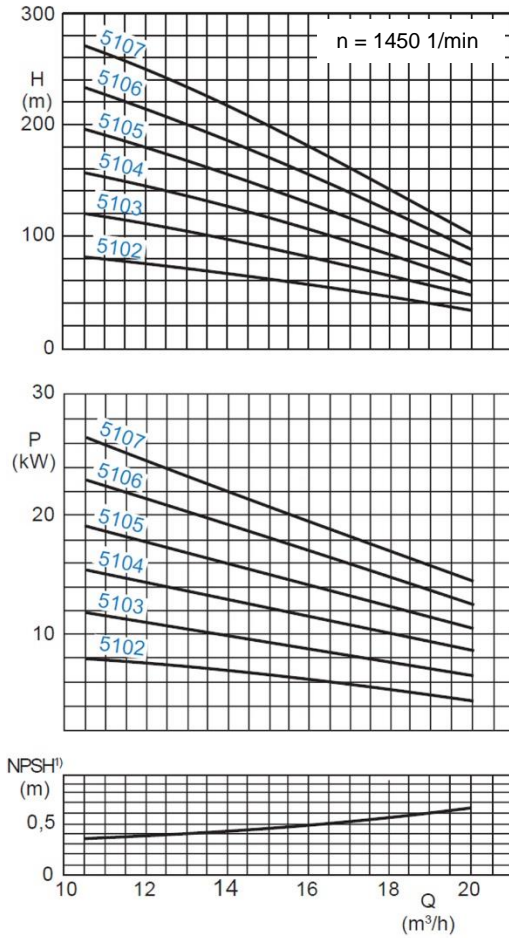

Values are valid for water at 1 kg/dm³ and Viscosity at 1 cSt.

Capacity ± 5% - Delivery head ± 5% - Power + 10%

For designs with a mechanical seal or a casing seal of soft Teflon, the tolerance for the delivery head is extended by 2% each.

Pump size	Motor		Base plate	Coupling BDS	Weight [kg]		Dimensions [mm]													
	kW	size			Pump	Set	a	b2	c	d	e1	e2	v	f1	h3	m1	m2	w*	w1	
5102/7	5.0	132S	P017	103	80	180	455	361	25	15	700	325	200	-28	220	503	465	1180	1100	
	6.8	132M				232														1191
5103/7	6.8	132M	P385	103	90	252	530	490	30	24	740	440	200	-28	240	578	540	1266	1140	
	10.0	160M	P436			292	540												1353	1270
5104/7	10.0	160M	P487	103	101	325	605	610	35	28	940	550	240	-28	260	653	615	1428	1420	
	13.5	160L				347														1472
5105/7	10.0	160M	P487	103	111	335	680	610	35	28	940	550	240	-28	260	728	690	1503	1420	
	13.5	160L				357														
	15.0	180M	P538	395	660	1060	600	280	280	280								1640	1620	
5106/7	13.5	160L	P538	118	121	408	755	660	35	28	1060	600	280	-28	260	803	765	1622	1620	
	15.0	180M				429														
5107/7	15.0	180M	P538	118	132	440	830	660	35	28	1060	600	280	-28	280	878	840	1790	1620	
	17.5	180L				463														

* Dimensions depend upon the motor brand

1) A safety margin of 1 m has to be added when using a liquid containing gas.

Dimension chart, pump set drawing and performance curves

CEH 6100/7 (with retaining stage)

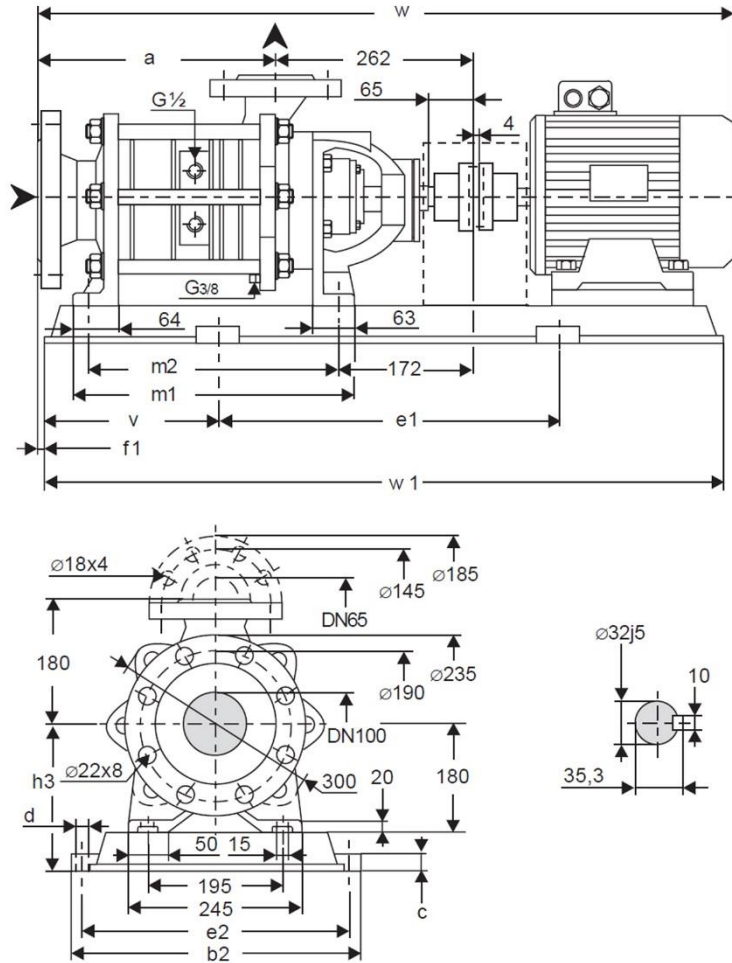
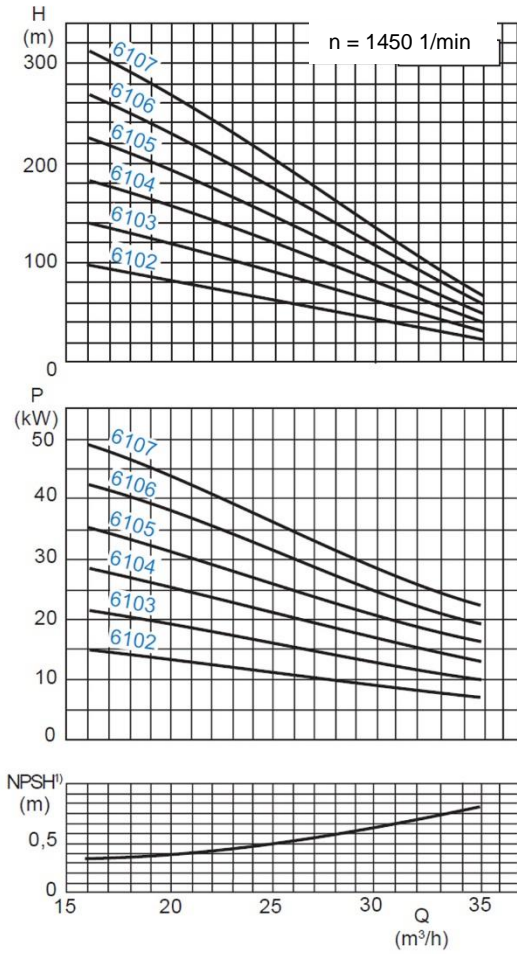

Values are valid for water at 1 kg/dm³ and Viscosity at 1 cSt.

Capacity ± 5% - Delivery head ± 5% - Power + 10%

For designs with a mechanical seal or a casing seal of soft Teflon, the tolerance for the delivery head is extended by 2% each.

Pump size	Motor kW	Motor size	Base plate	Coupling BDS	Weight [kg]		Dimensions [mm]												
					Pump	Set	a	b2	c	d	e1	e2	v	f1	h3	m1	m2	w*	w1
6102/7	6.8	132M	P385	103	105	267	518	490	30	24	740	440	200	-35	260	571	533	1279	1140
	10.0	160M	P436			307	540	840			490	215						1366	1270
6103/7	10.0	160M	P487	103	117	331	608	610	35	28	940	550	240	-35	280	661	623	1456	1420
	13.5	160L				363												384	
6104/7	15.0	180M	P538	118	130	439	698	660	35	28	1060	600	280	-35	280	751	713	1683	1620
	17.5	180L				461									540			1738	
6105/7	24.0	200L	P538	135	142	450	788	660	35	28	1060	600	280	-35	280	841	803	1773	1620
	17.5	180L				473									485			1828	
6106/7	24.0	200L	S389	135	155	391	878	540	40	28	1200	490	300	-35	280	931	893	1863	1800
	30.0	225S	470			620									1918			2018	
6107/7	24.0	200L	S389	135	167	482	968	540	40	28	1200	490	300	-35	300	1021	983	2008	1800
	30.0	225S	532			630									2003			2080	
	36.0	225M	14211			152									630			740	

* Dimensions depend upon the motor brand

¹) A safety margin of 1 m has to be added when using a liquid containing gas.

Sterling SIHI GmbH

Lindenstr. 170, 25524 Itzehoe, Germany

Telephone +49 (0) 4821 771-01

Telefax +49 (0) 4821 771-274

www.sihi.com