

Particle separator

Particle separator

AT 8073

Dimension range G 3/4 - G 2	PN 6/10	Temperature range 0 °C to 110 °C	Material Brass
---------------------------------------	-------------------	--	--------------------------

For separation of magnetic and non-magnetic dirt particles in heating and cooling systems where the fluid is water. Can also, at extended inspection, be mounted in systems with mixtures of water/glycol and water/ethanol. However not in a system with mixtures of water/salts.

Program text

PMB.222 Sludge separator

Particle separator AT8073-XX of brass with a surface magnet. For both vertical and horizontal mounting.

Quality assurance

Fulfills AFS 1999:4 8§ standards and shall not be CE-marked.

All separators are functional- and density tested.

Details

1	Connections, internal thread
2	Body of brass
3	Surface magnet, removable.
4	Valve for manual washout.

Dimensions and weight

Connection	G 3/4	G 1	G 1 1/4	G 1 1/2	G 2
A	90	90	128	128	128
B	143	152	163	169	183
C	152	152	196	196	196
Weight	2,2	2,3	3,6	3,7	3,9

Dimensions in mm, weight in kg

Technical information

Connection	20	25	32	40	50
Nom. flow m ³ /h	1,3	2,0	3,6	5,0	7,5
Pressure drop kPa	1,9	3,9	2,2	2,6	5,8
Max. operation pressure bar	6	6	10	10	10

Values above apply at max. speed 1 meter/second.

Function and design

AT8073 separates effectively dirt particles in heating and cooling systems. The surface magnet attracts magnetic particles in the separator as well. The collected dirt is easily drained by pulling the magnet down and then opening the drain valve.

The separator can be installed both horizontally and vertically thanks to the 360° rotatable connection part.

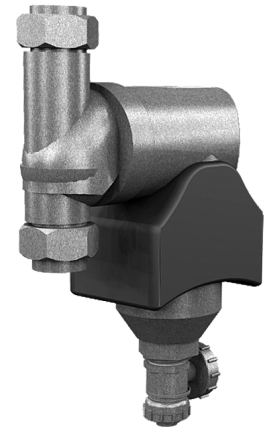

AT8073xxi

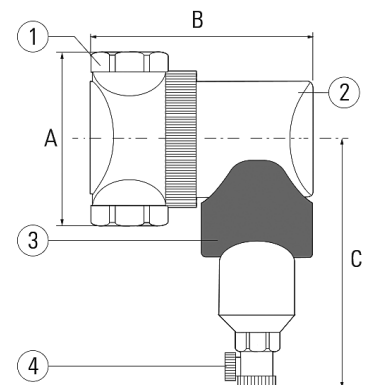

Particle separator

Particle separator

AT 8073

Installing

Works well in both heating and cooling systems. Mounted on a main line before important machines such as boilers, heat exchangers and refrigerators.

Maintenance and spare parts

For a safe- and good operation the separator should be regularly checked and cleaned.

Marking

Marked with dimensions, max operation pressure, type-No. and the manufacturer's name.

How to order

Example: AT 8073-20

Connection	AT-No.
G 3/4	8073-20
G 1	8073-25
G 1 1/4	8073-32
G 1 1/2	8073-40
G 2	8073-50