

Electric actuator

Bernard electric

AT 3910 (45-150 Nm)

Internet_Variants

Range of application

Weather-proof actuator for On/Off, positioning or modulating maneuvering for ball- and butterfly valves. Torque from 45-150 Nm.

UEC.11 Actuator for valve, electric, two-position without spring return

Actuator Bernard Electrical AT 3910 for 90° maneuvering of ball valves, butterfly and where a 90° rotation is needed.

The actuator is manufactured according to desired properties, contact Armatec for more information.

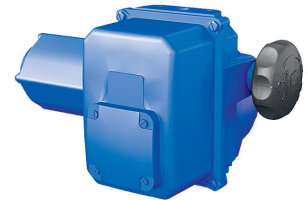

Quality assurance

CE marked

EC directives 2004/108/EC, 2006/95/EC, following the standards of EN 61000-6-4, EN 61000-6-2, EN 60034-1 och EN 60529.

IP 67 rated

Material specification

	Detail	Material	Surface treatment
1	Body	Aluminum	Zinc primer, epoxy layer and RAL 5002 blue polyurethane top coat
2	Cover	Aluminum	Zinc primer, epoxy layer and RAL 5002 blue polyurethane top coat
	Drive	Massive	
3	shaft	steel	Untreated

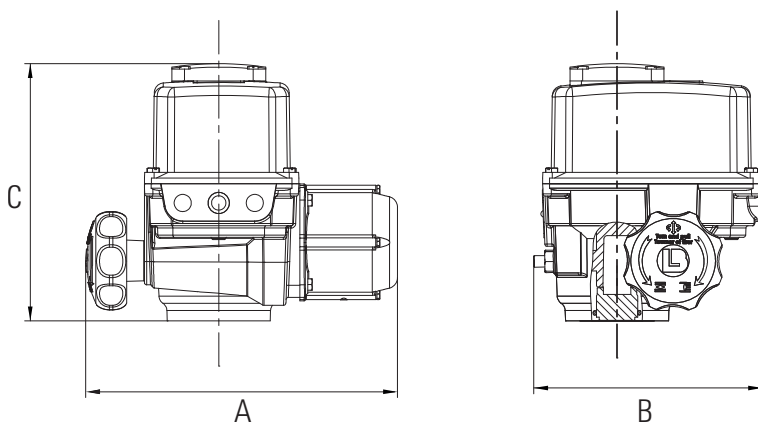

Electric actuator

Bernard electric

AT 3910 (45-150 Nm)

Dimension and weight

Actuator / Fig nr	Drive shaft*	A	B	C	D	E	F	G	H	Weight
3910-4	Depending on valve	273	200	225	116	73	74	40	95	6
3910-6	Depending on valve	319	200	225	116	73	74	40	95	7
3910-10	Depending on valve	319/362	200	225	116	73	74	40	95	7
3910-15	Depending on valve	362	200	225	116	73	74	40	95	7

Dimension in mm, weight in kg. *Possible to get in requested size, parallel, keyway or a 45° rotation.

Dimension and weight

Actuator / Fig. no	Drive shaft*	A	B	C	D	E	F	G	H	Weight
3910-6X	Depending on valve	454	200	225	116	73	74	25	95	7
3910-10X	Depending on valve	454/497	200	225	116	73	74	25	95	7
3910-15X	Depending on valve	497	200	225	116	73	74	40	95	7

Dimension in mm, weight in kg. *Possible to get in requested size, parallel, keyway or a 45° rotation.

Dimension and weight

Actuator / Fig. no	Drive shaft*	A	B	C	D	E	F	Weight
3910-6-6A3P	Depending on valve	319	389	305	116	73	74	14
3910-15-8A3P	Depending on valve	362	389	305	116	73	74	14

Possible to get in requested size, parallel, keyway or a 45° rotation.

Function and design

Standard version

Reversible actuator in four different sizes for 90° movement, adjustable through a combination of cams, mechanical end stop and/or torque switches.

The actuator is a compact combination of an electric motor with thermal protection and a self-locking worm gear. As standard with a hand wheel and position indicator.

The actuator mounting dimensions in relation to the fittings are according to ISO 5211.

Vibrations resistant to 1 g, (9.8 m / s²) at 10-500 Hz.

Design lifetime 20 000 cycles for On/Off or 300 000 starts for positioning. Tested according to EN 15714-2 class A and B

Electric actuator

Bernard electric

AT 3910 (45-150 Nm)

Standard performance

Standard performance	
Motor duty	S4-30% ED, 360 starter/h max. S4-50% for modulating class III S4-100% for continues modulating
Enclosures	IP67, IP 68 optional, EX classified as optional
Temperature	-20°C to +60°C
Anti condensation heater	Included as standard
Thermal overload protection	Thermostat
Permanently lubricated gear	Yes
Cable entries	Depending on actuator model
End travel switches	4 as standard
Torque switches	No
Terminal block	8 connections

Technical data

Actuator 3910 on/off	Torque Nm		Operating time (50 Hz) s	ISO-connection	230 V AC 50 Hz Ampere			400 V AC 50 Hz Ampere			24 V DC	24 VAC
	Sto p	Sto p			Start	Stop	kW	Start	Stop	kW	Operating time	Operating time
4	45	45	6*	F05/07	0,9	0,8	0,03	-	-	-	-	6
6	60	60	6*	F05/07	0,9	0,6	0,03	0,5	0,3	0,03	6	6
10	100	100	6, 35, 60	F05/07	1,7	1,2	0,06	1,1	0,6	0,10	35	35
15	150	150	15, 25	F05/07	0,9	0,6	0,03	0,5	0,3	0,03	15	15

*Other times on request

Accessories and options

Standard version, see above.

Possible options and variants

Actuator Intelli+, see separate datasheets for possible features, such as summer alarm, bus-control, travel-time control etc.

Power supply 3-phase

380/415 V - 50Hz, 440/460 V - 60 Hz

230 V - 50 Hz, 220/230 V - 60 Hz

500 V - 50 Hz eller 5775 V - 60 Hz

1-Phase

110, 115, 120, 220 V - 50 Hz

115 V-60 Hz

24V - 50 Hz

DC

24, 48, 110 or 220 VDC

For other time periods, contact Armatec

For off-shore painted actuators, contact Armatec

For ATEX-rated actuators, contact Armatec

Installation

During all work with the actuator the power **MUST** be disconnected.

- The actuator must be connected as per the wiring diagram, see the manual.
 - Each actuator must be powered by an individual switch or relay contact, minimum 16A, to prevent cross-feed between the actuators.
 - At outdoor installation, the actuator should preferably be protected by a roof or cap.
 - Installation with the motor downwards should be avoided.
 - Turn the valve with the control unit's hand wheel to centre position. See indication on top of the device.
 - Always connect the heater.
 - Check that the actuator turns the valve in the desired direction.
 - The correct limit switch (open or closed) shall break the motor current.
 - Cable entries must comply at least to the lowest protection class of devices.
- See the manual for start-up, storage and maintenance.

Marking

Article number, manufacturer, serial number, voltage and current.
Wiring diagram is placed by the motor at delivery.

Options for control

Control signal	230 V, 50 Hz	3-phase 400 V, 50 Hz	24 V
4-20 mA or 0-10 V	Minigam, Integral, Posigam	Intelli, Integral, Posigam	Intelli, Integral, Posigam
Profibus DP	Intelli, Integral, Posigam	Intelli, Integral, Posigam	Intelli, Integral, Posigam

How to order

Example: 3910-4-3A3A					
AT3900	-4*	3**	A***	3****	A*****
Fig. no	Size	Operating time	Connection	Voltage	Options
* 4, 6, 10 or 15 depending on needed torque					
** =Time: 3s, 2=5s, 3=6s, 4=10s, 5=15s, 6=20s, 7=25s, 8=30s, 9=35s, 10=45s, 11=50s, 12=60s					
*** A=F05/07					
**** 0=24 VDC, 1=24 VAC, 3=230 VAC, 4=400 VAC					
***** A=On/Off, B=Integral, C=Posigam, D=Minigam, E=1000 ohm POT, P=Intelli+					